

# Essential Desk 48x24 Two Leg

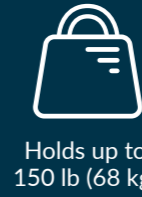

# vari®

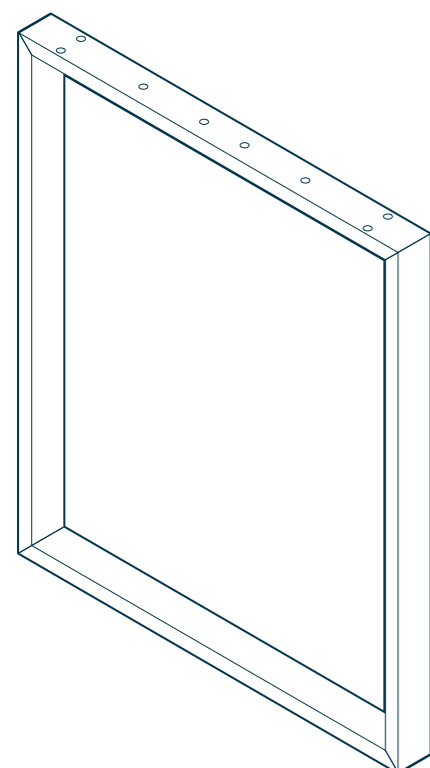
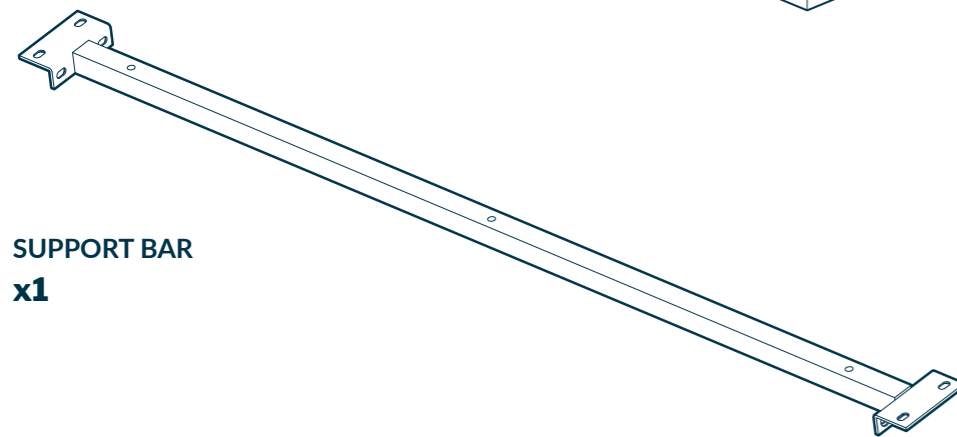
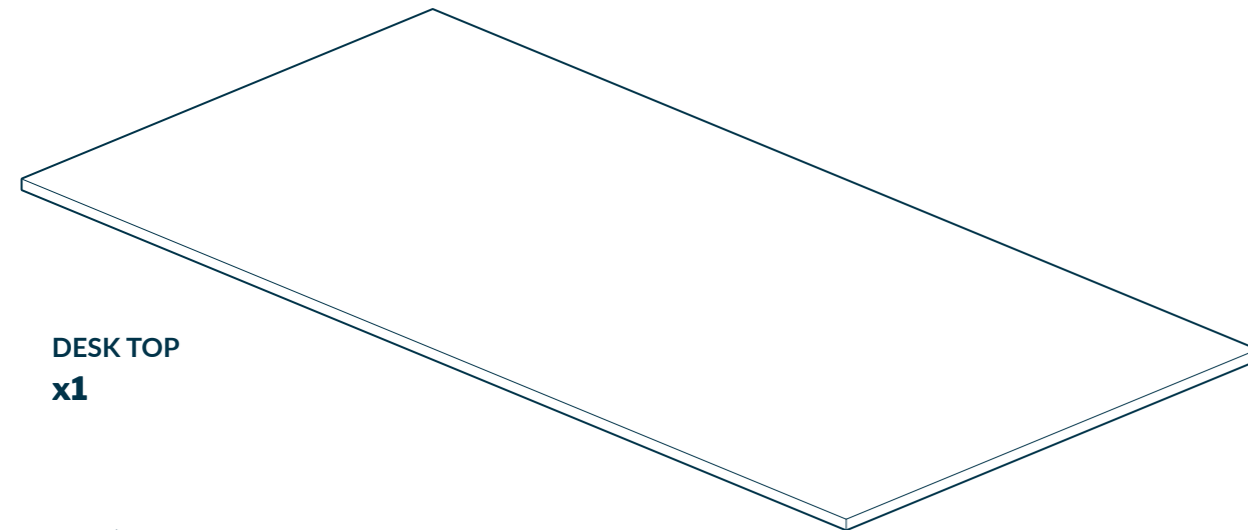

M6-20 SCREW  
x5 (1 spare)

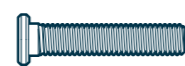

M6-30 SCREW  
x13 (1 spare)



M6-35 SCREW  
x8 (1 spare)



M6 ALLEN KEY  
x1

1

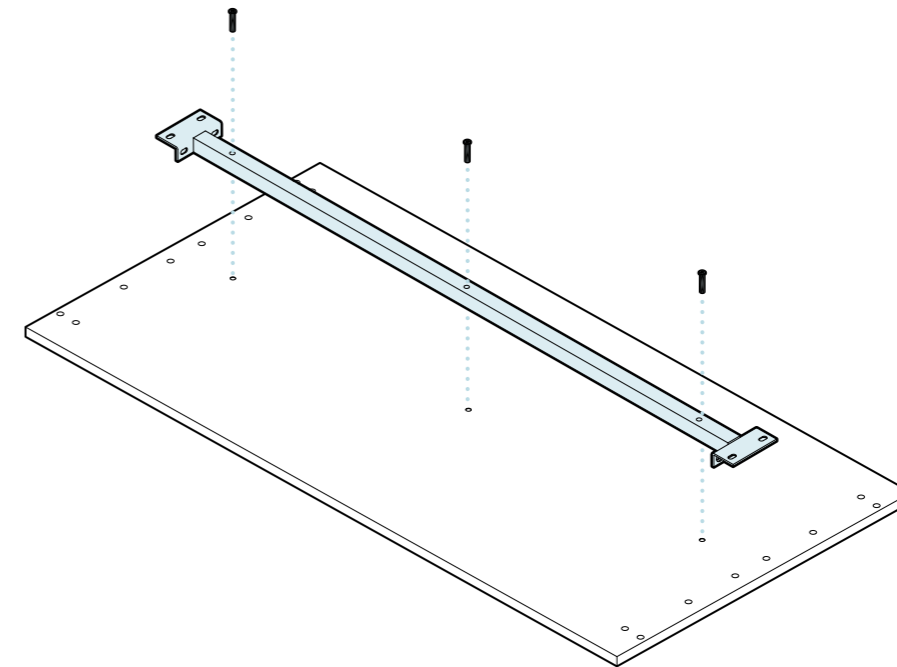

Place the Desk Top upside down on the box. Secure the Support Bar to the Desk Top with three (3) M6-35 screws. **Hand-tighten only (do not tighten them completely).**

2

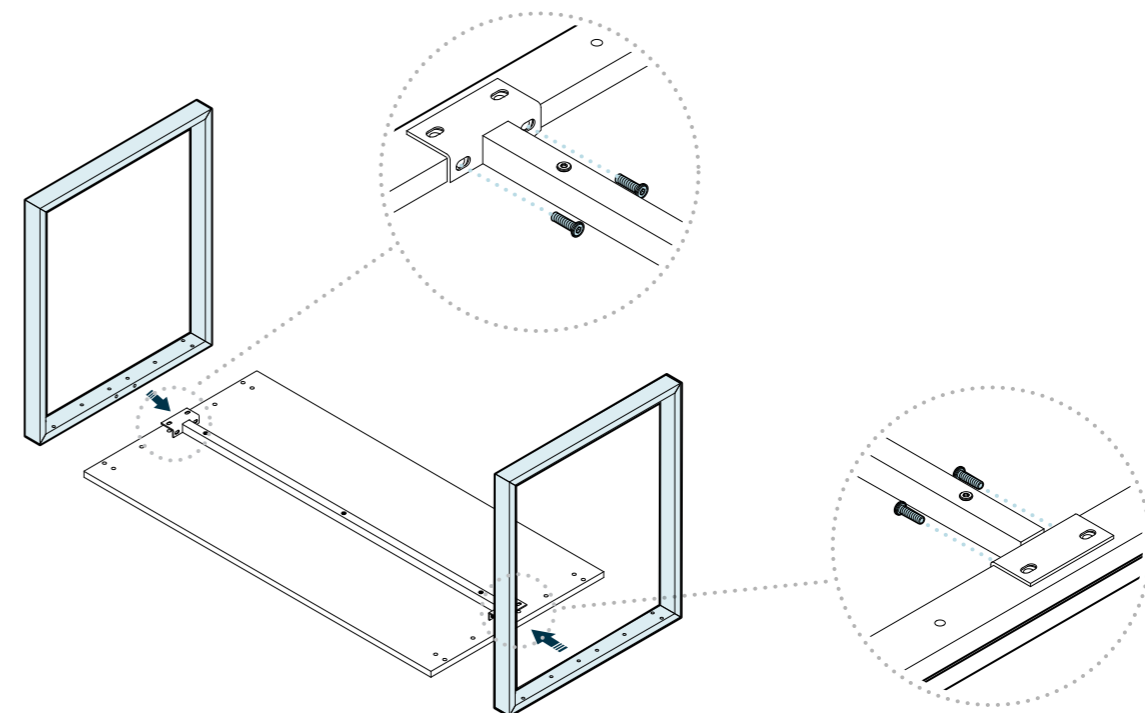

Secure legs to Support Bar with four (4) M6-20 screws. **Hand-tighten only (do not tighten them completely).**

3

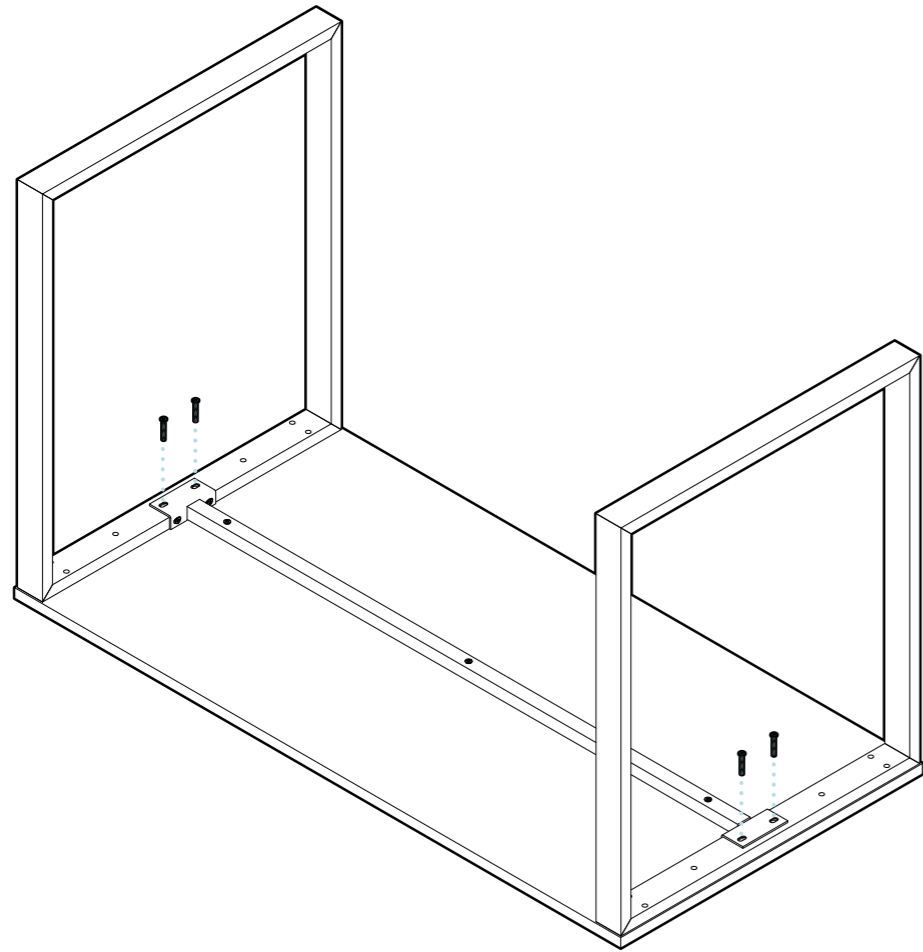

Secure the Legs to the Support Beam using four (4) M6-35 screws.

4

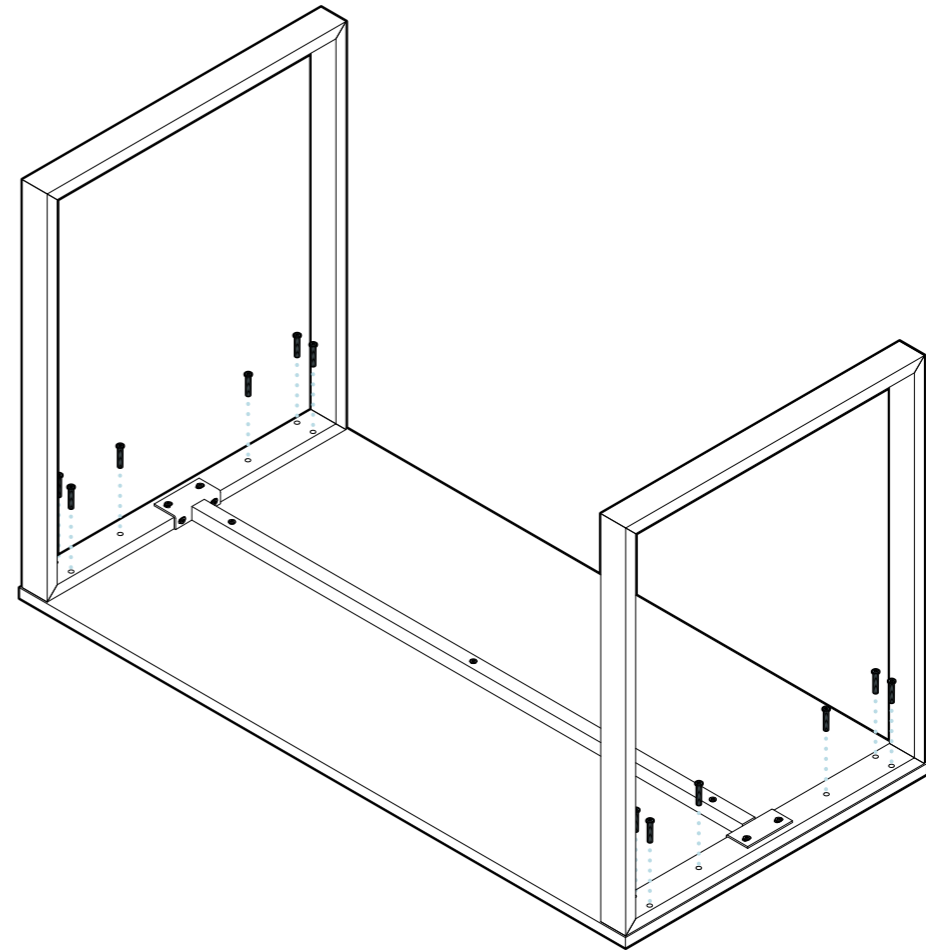

Using twelve (12) of the M6-30 Screws, secure the Legs to the Desk Top. **Using the Allen key, tighten all of the screws.**

5

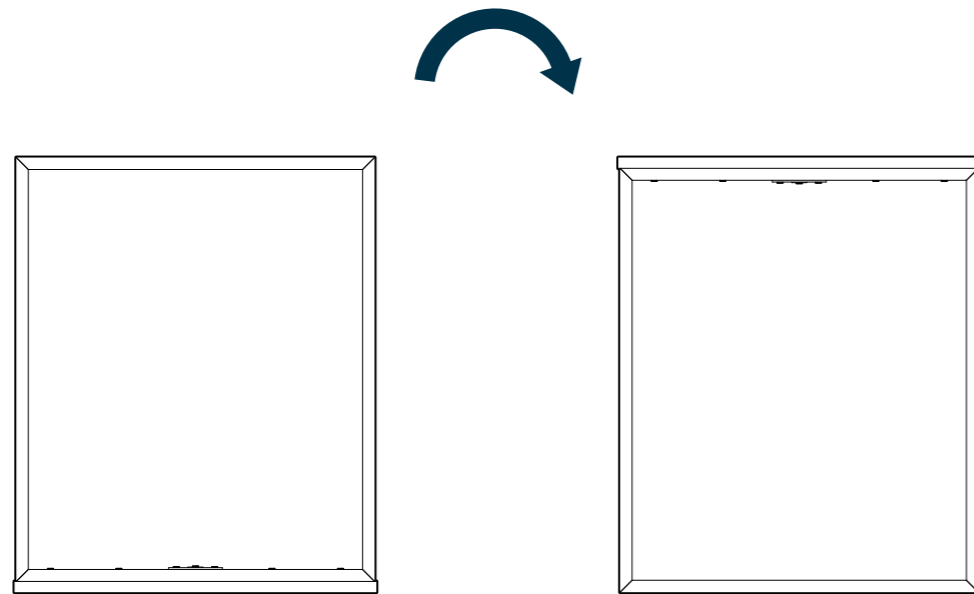

Using two people, flip the desk over until the Desk Top is facing upward.