

Split Top



Holds up to 150 lb (68 kg)



2 People Required for Assembly

Included Parts



x1
DESK TOP



x1
LEG



x1
LEG WITH
MOTOR

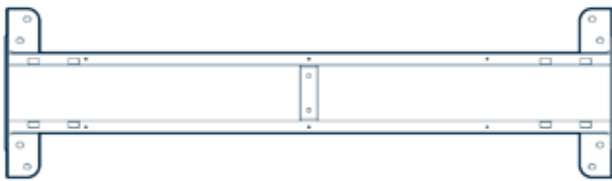

x1
DESK FRAME

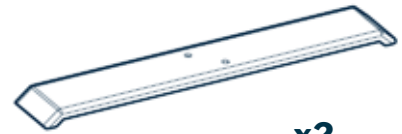

x2
FOOT



x1
TRANSMISSION SHAFT



x1
CONTROL
PANEL



x1
TRANSMISSION SHAFT COVER

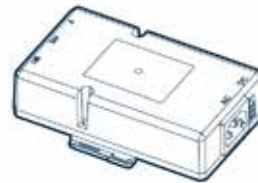

x1
CONTROL
BOX



x10
M6-16 BOLT WITH
FLAT WASHER AND
SPLIT LOCK WASHER



x4
M6-14 BOLT



x4
M6 WASHER



x1
HEX WRENCH



x1
M6 ALLEN KEY



x4
M10-25 BOLT



x2
ADHESIVE CABLE CLIPS



x6
PUSH-IN RIVET PINS



x1
M10 ALLEN KEY

Desk Assembly

1

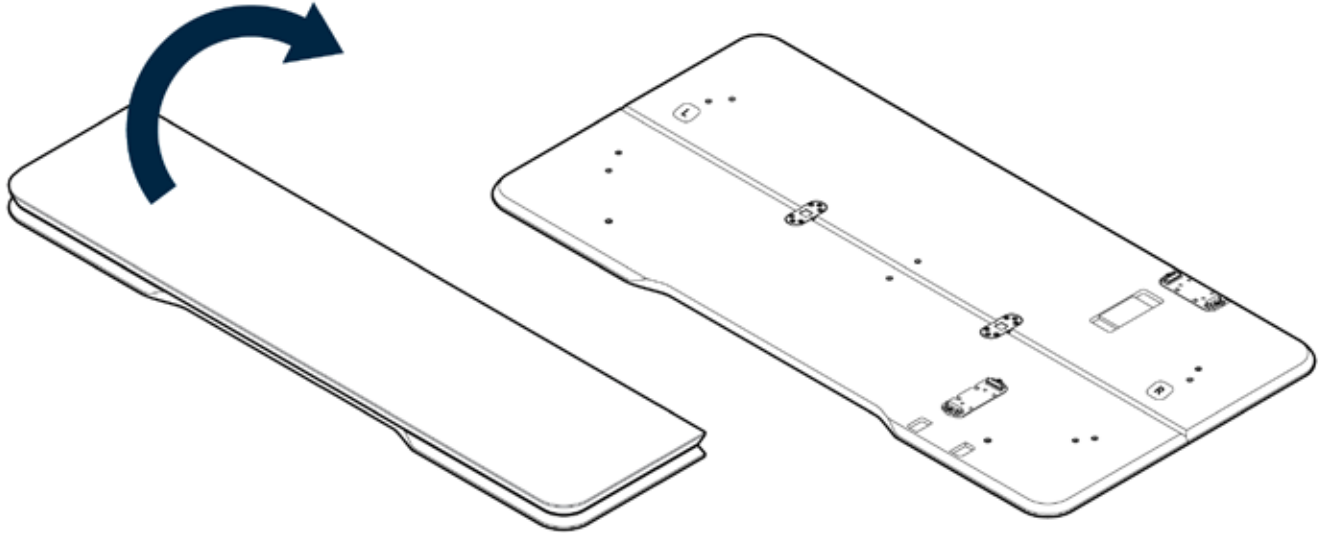

To protect the desk top surface during assembly, place the folded desk top face-down on a debris-free carpeted area or blanket. Unfold the desk top until it is flat and the surface is flush with the floor.

2

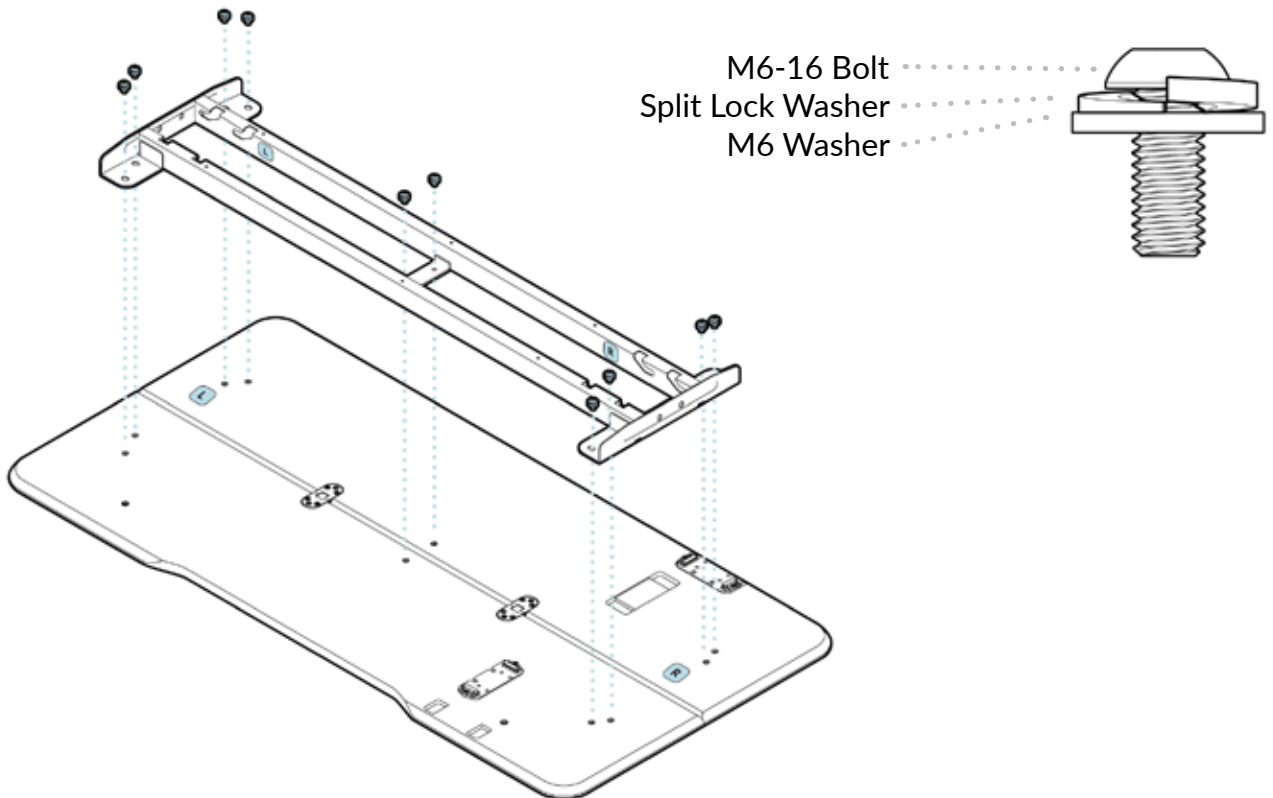

Line the frame up with the ten (10) pre-drilled holes on the desk top. Be sure to orient the frame on the desk top properly (see above), using the L and R stickers on the frame and desk top. Use the ten (10) provided bolt assemblies (pictured in the illustration above) to secure the frame to the desk top.

3

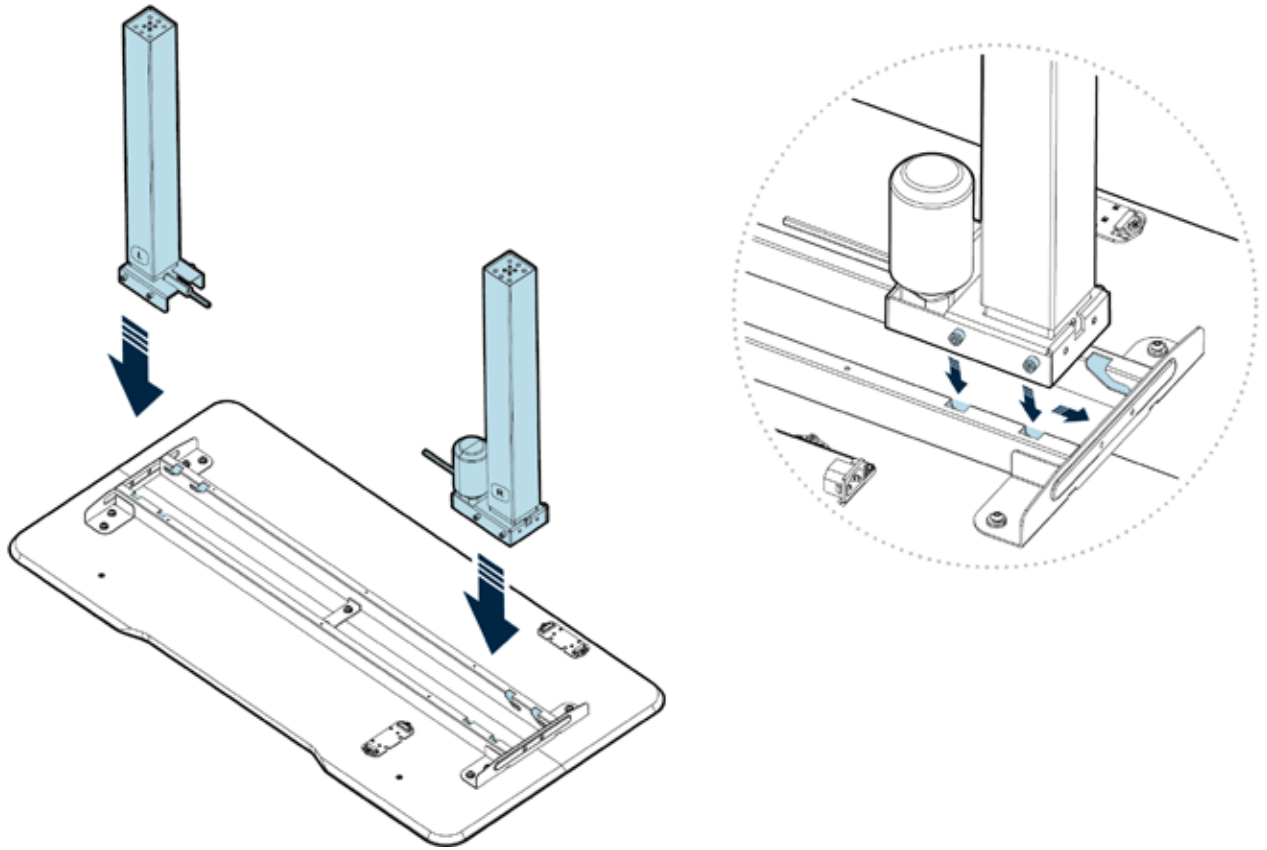

Locate the four slots on either side of the desk frame. Next, using the locator pins on the base of each leg, slide the legs into place. Be sure to place the leg with the motor on the same end as the control panel and control box brackets.

4

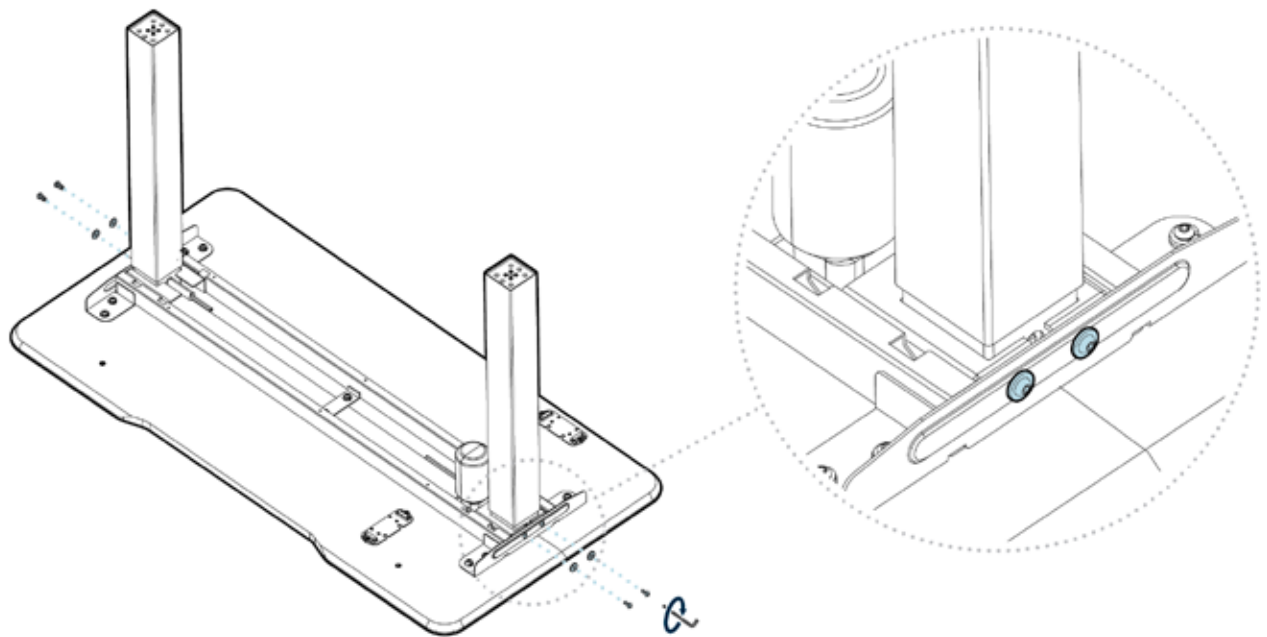

Using four (4) M6 washers, four (4) M6-14 bolts, and the M6 Allen key, turn clockwise to secure both legs into place.

5a

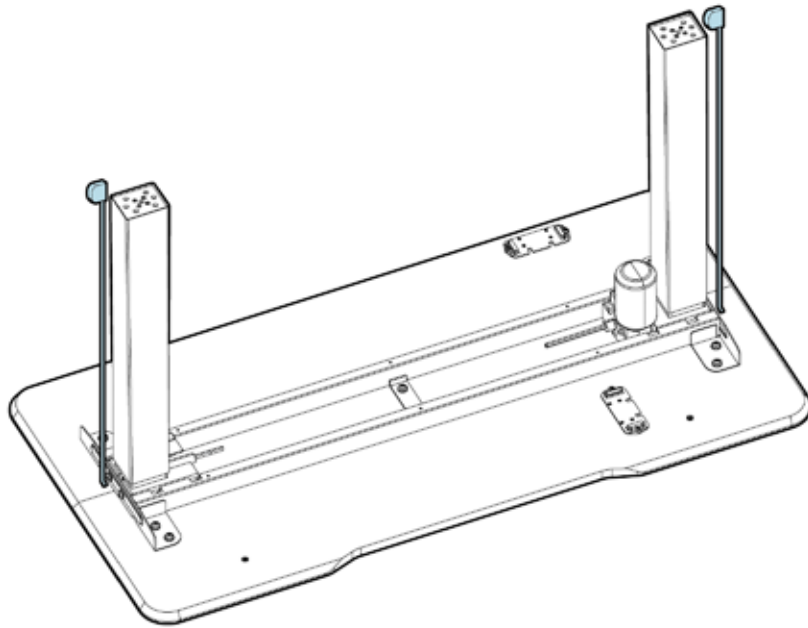

Use a tape measure to compare the height of the two legs. If the height difference is less than 2mm, move on to step 6. If the difference is greater than 2mm, proceed with the below step 5b.

5b

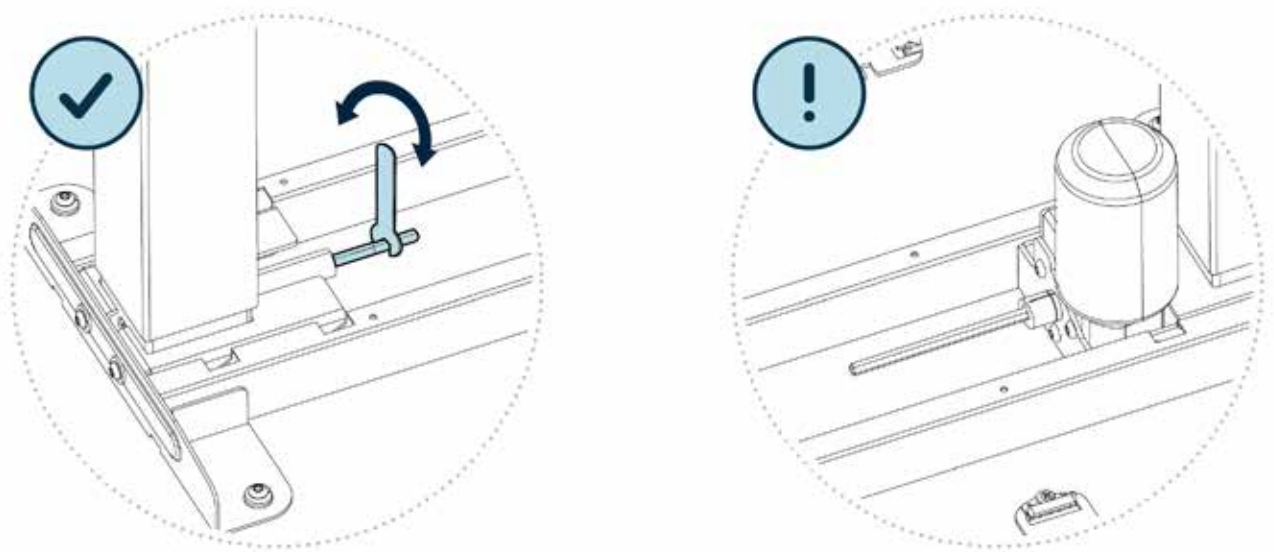

Locate the leg without the motor. Using the hex wrench, rotate that leg's hexagonal rod to adjust the height of the leg. Remeasure the height of each leg; if the difference is less than 2mm, move on to step 6. If the difference is still greater than 2mm, repeat step 5b.

6

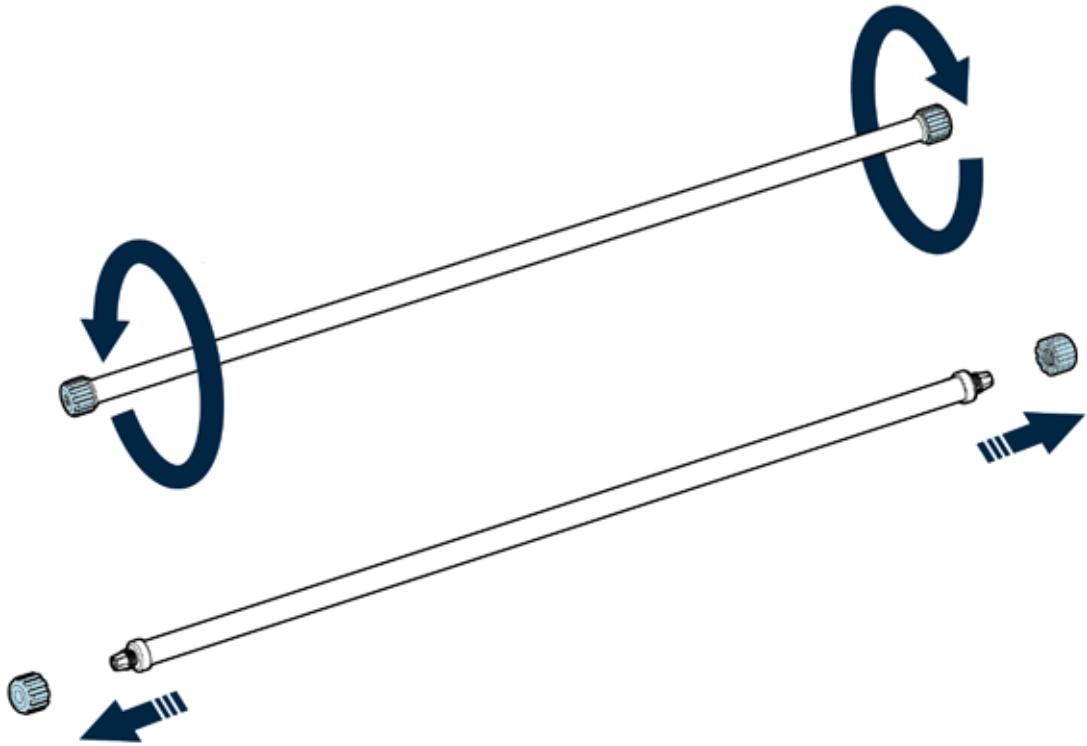

Loosen the nuts on either end of the transmission shaft by rotating them counter clockwise.

7

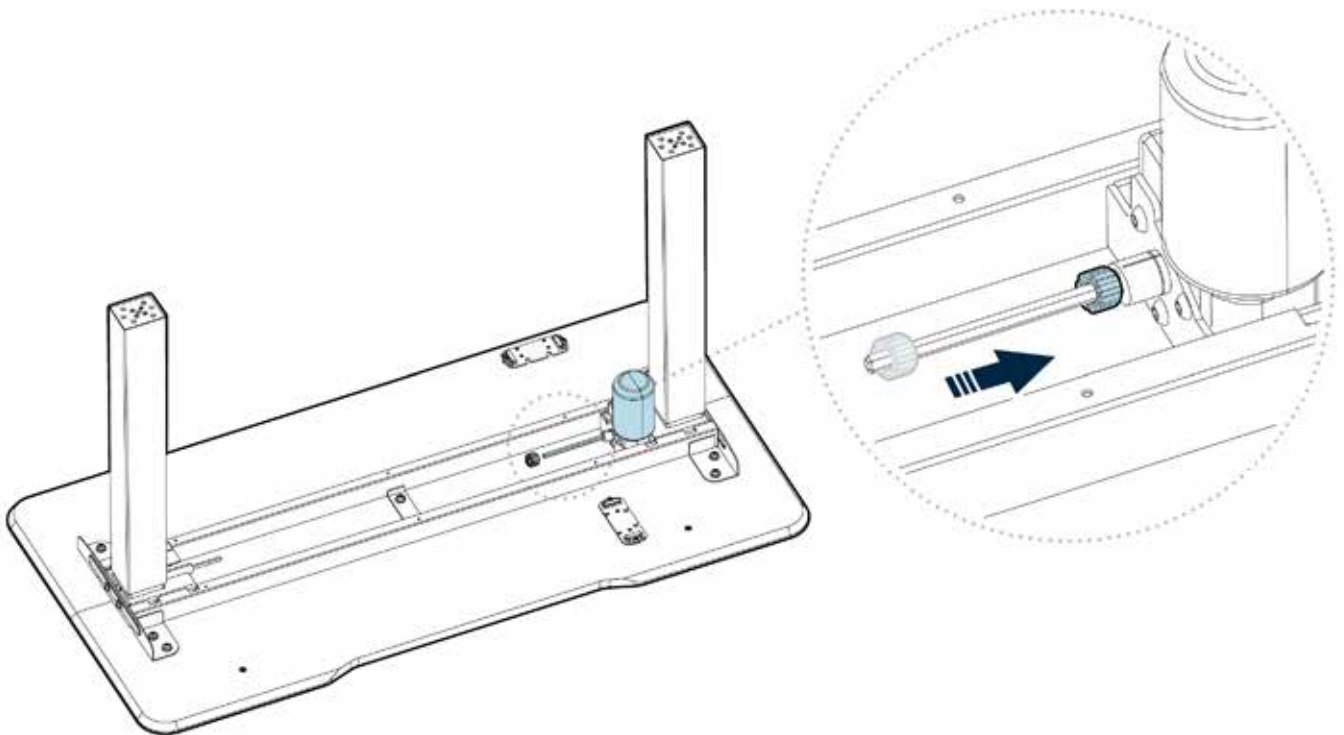

Insert one nut onto the hexagonal rod with the motor column, sliding it all the way onto the rod.

8

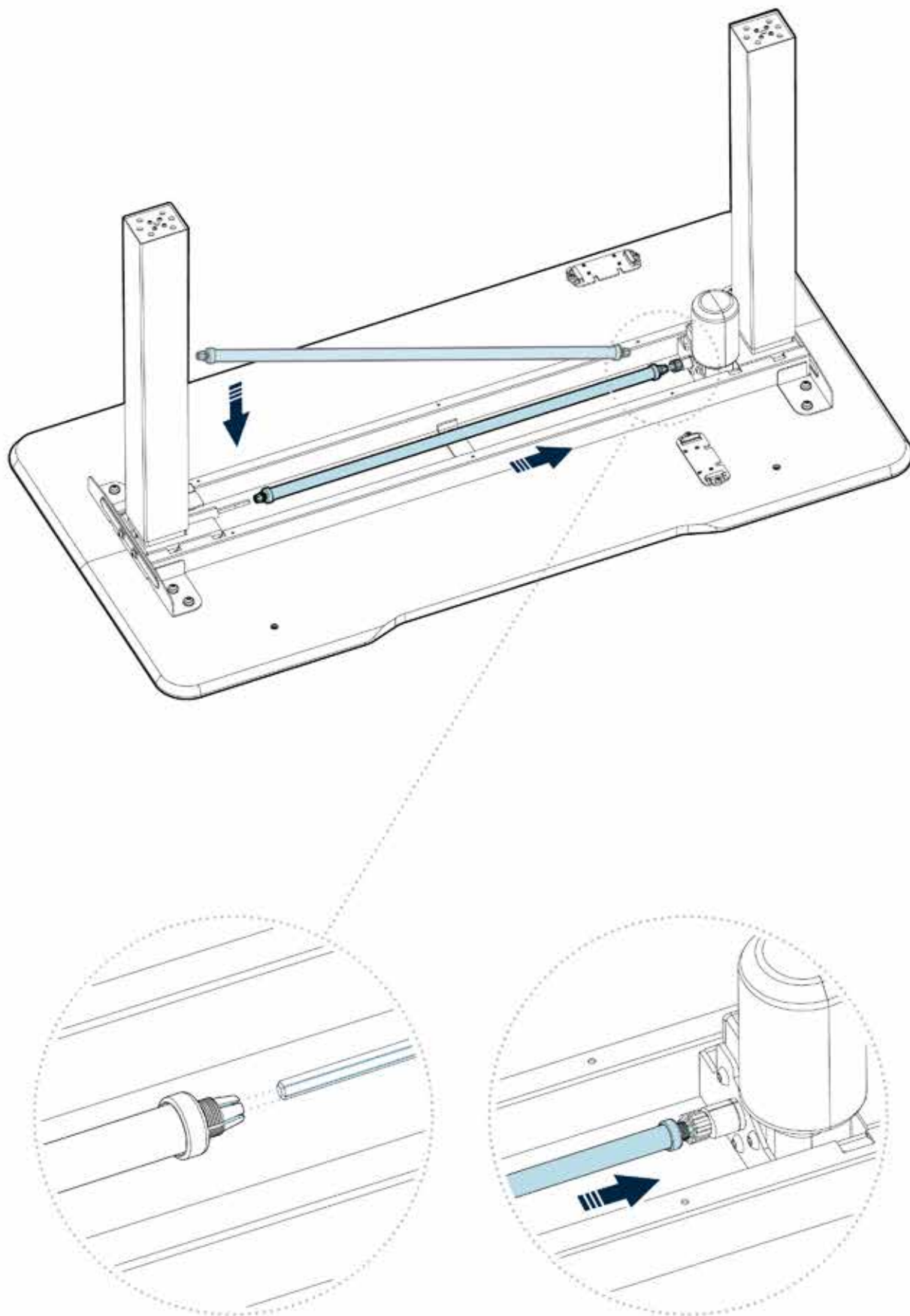

Angle the transmission shaft onto the same hexagonal rod that has the nut on it; ensure that the gaps on the tip of the transmission shaft are aligned with the edges of the hexagonal rod.

Slide the tip of the shaft to the nut, as shown above, but do **NOT** tighten the nut.

9

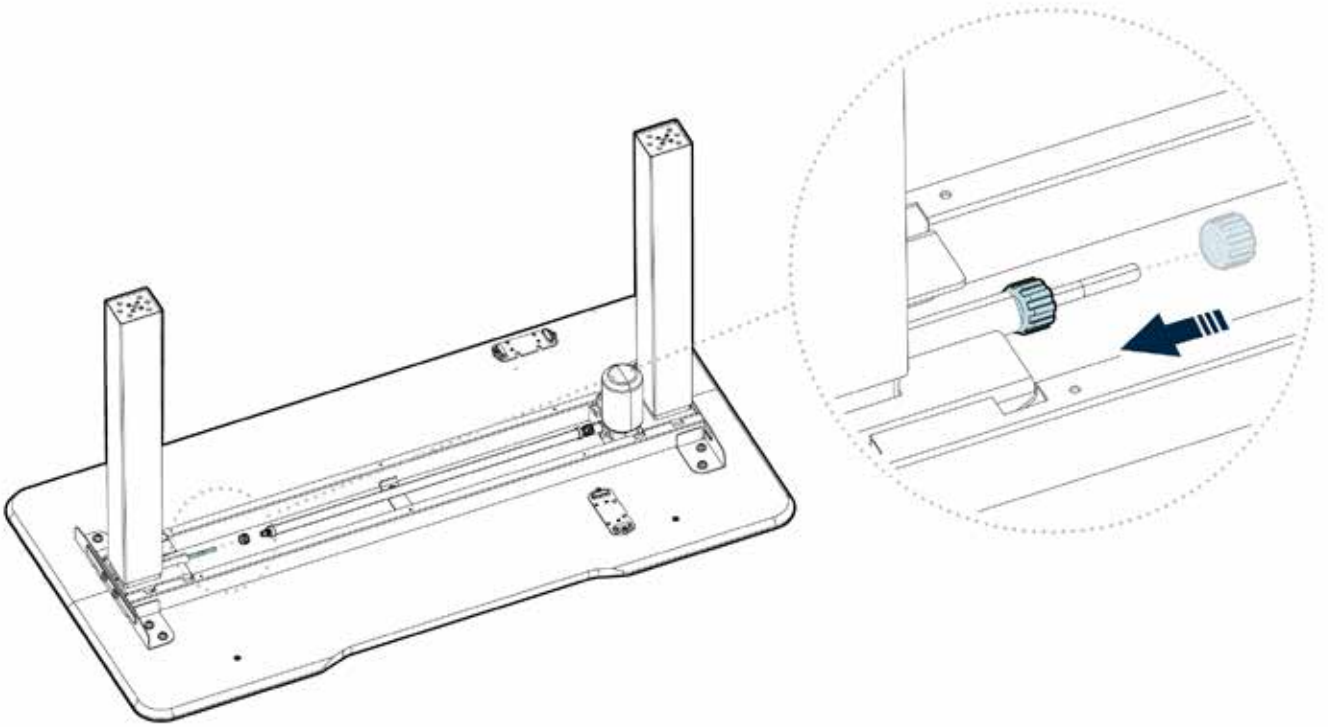

Insert the remaining nut onto the second hexagonal rod, sliding it all the way onto the rod.

10

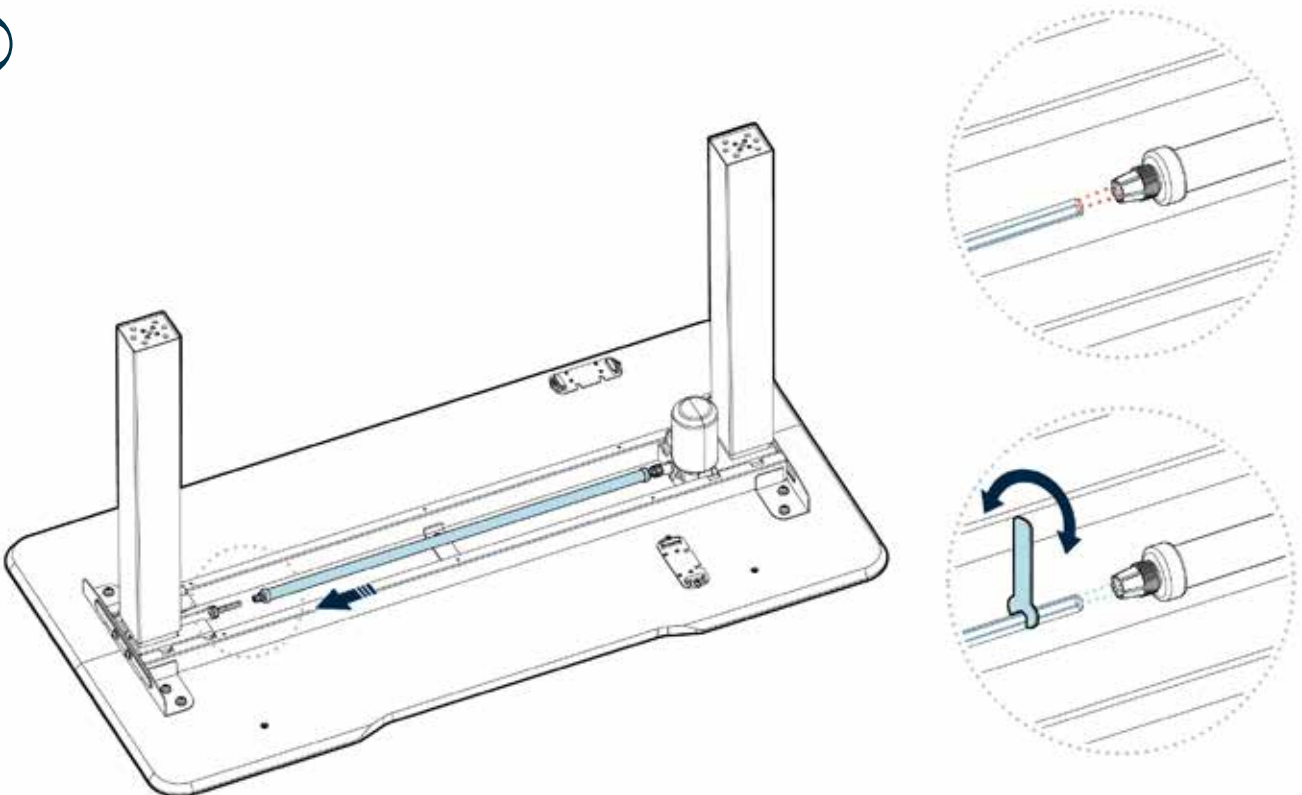

Slide the transmission shaft toward the end of the second hexagonal rod.

NOTE: The gaps on the tip of the shaft must be aligned with the ridges of the hexagonal rod. If they are not, use the hexagonal wrench to adjust the finely rotate the hexagonal rod.

11

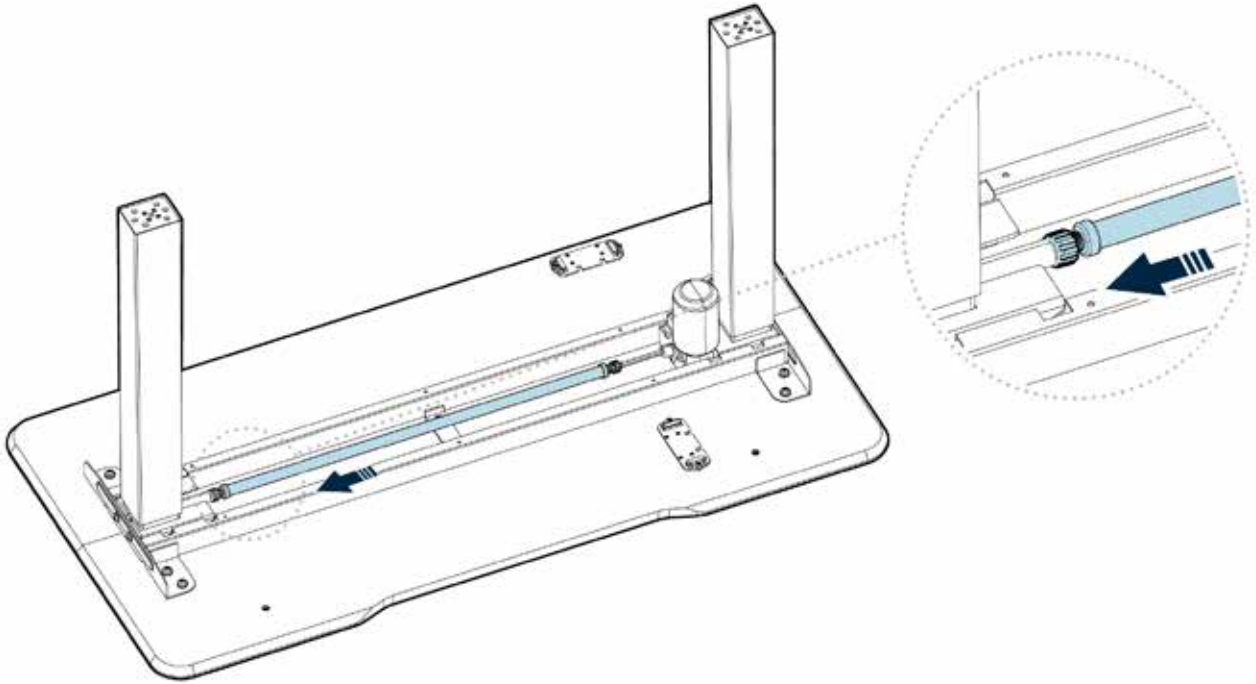

Slide the transmission shaft all the way to the nut on the hexagonal shaft **WITHOUT** the motor.

12

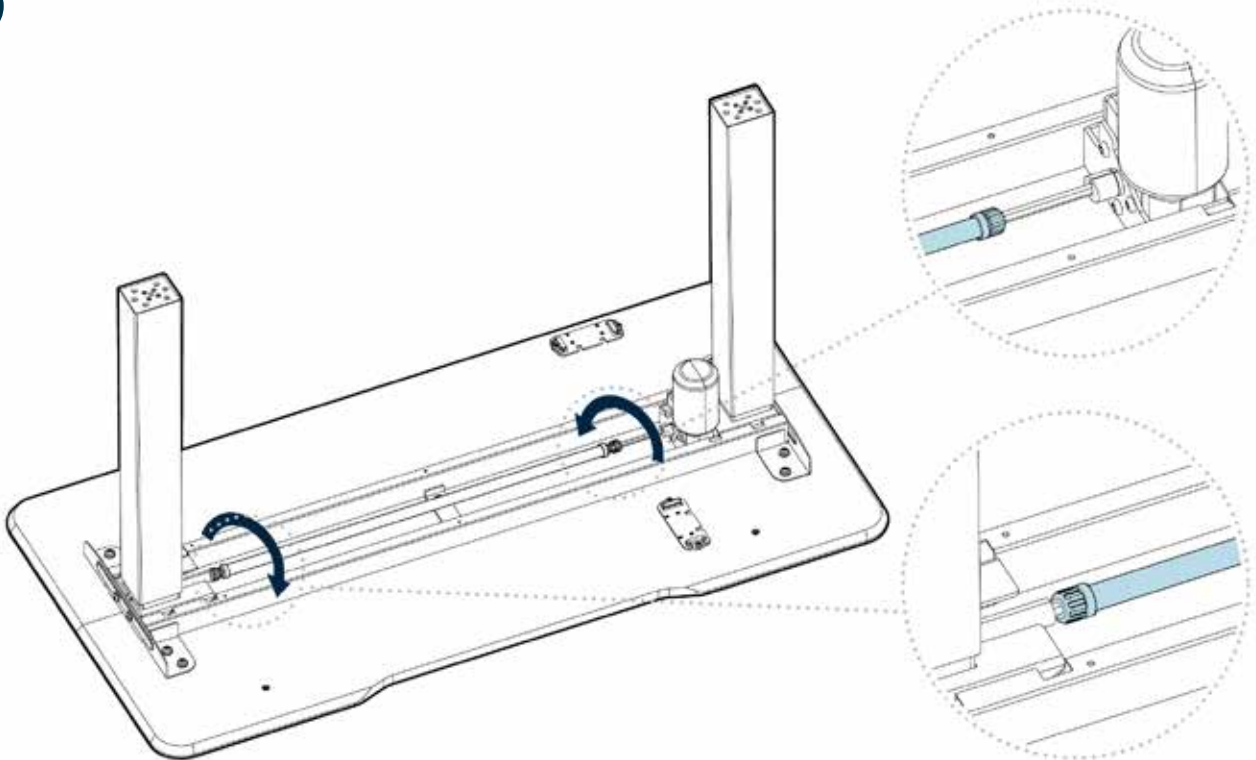

Tighten both nuts by twisting them clockwise.

13

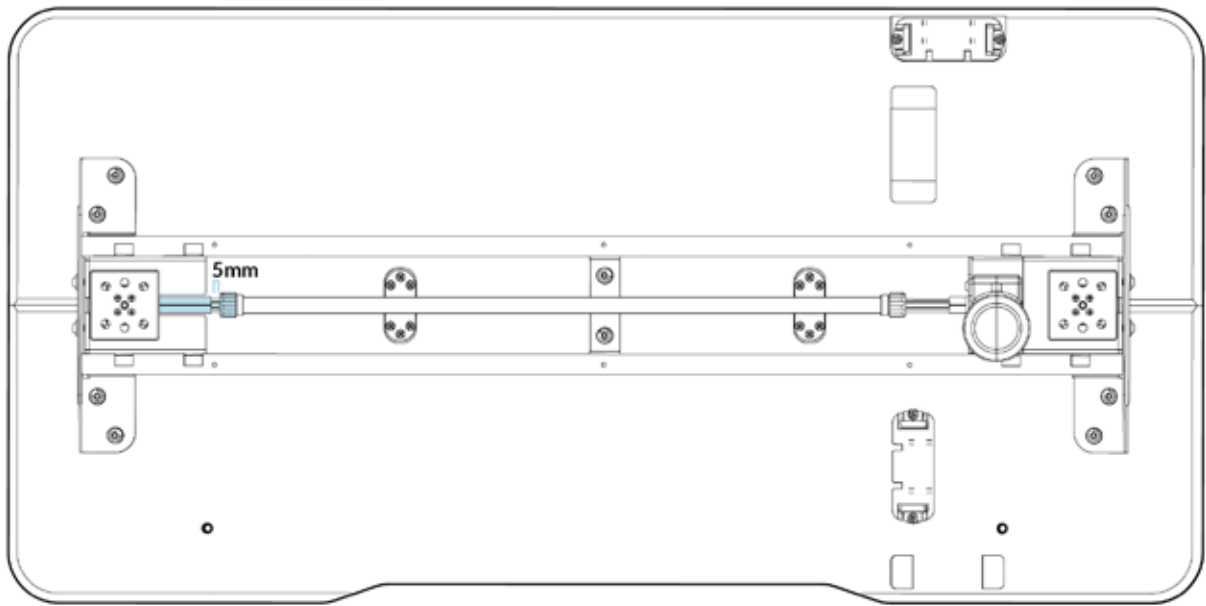

The gap between the end of the transmission shaft and the end of the hexagonal post AWAY from the motor should be approximately $\frac{1}{8}$ " (5mm), as shown above.

14

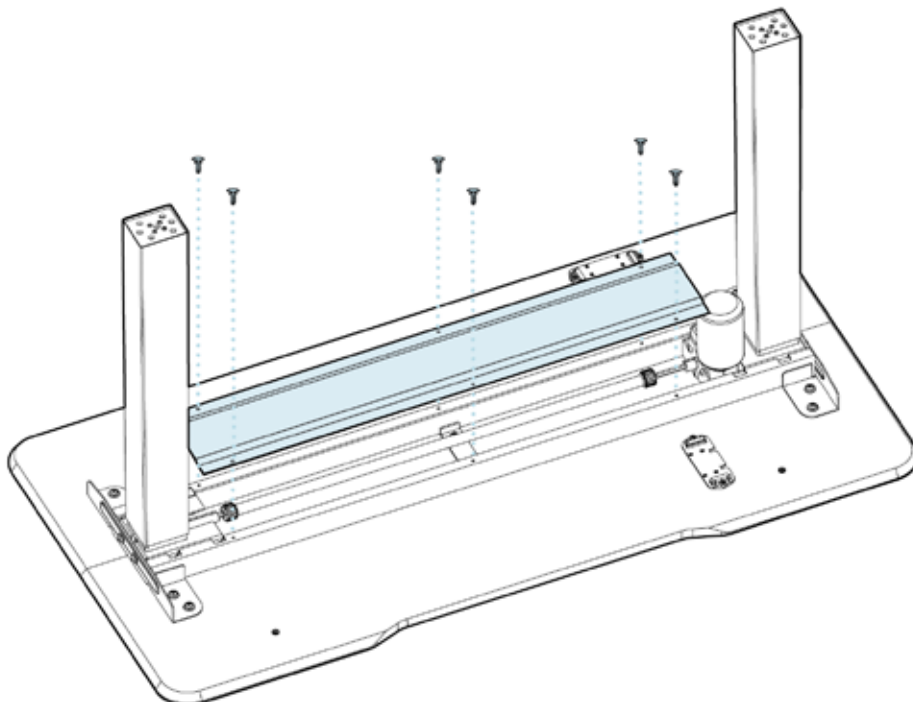

Next, locate the holes in the corners and middle of the transmission shaft cover and line them up with the six holes on the desk frame. Using the push-in rivet pins, secure the cover to the desk frame.

15

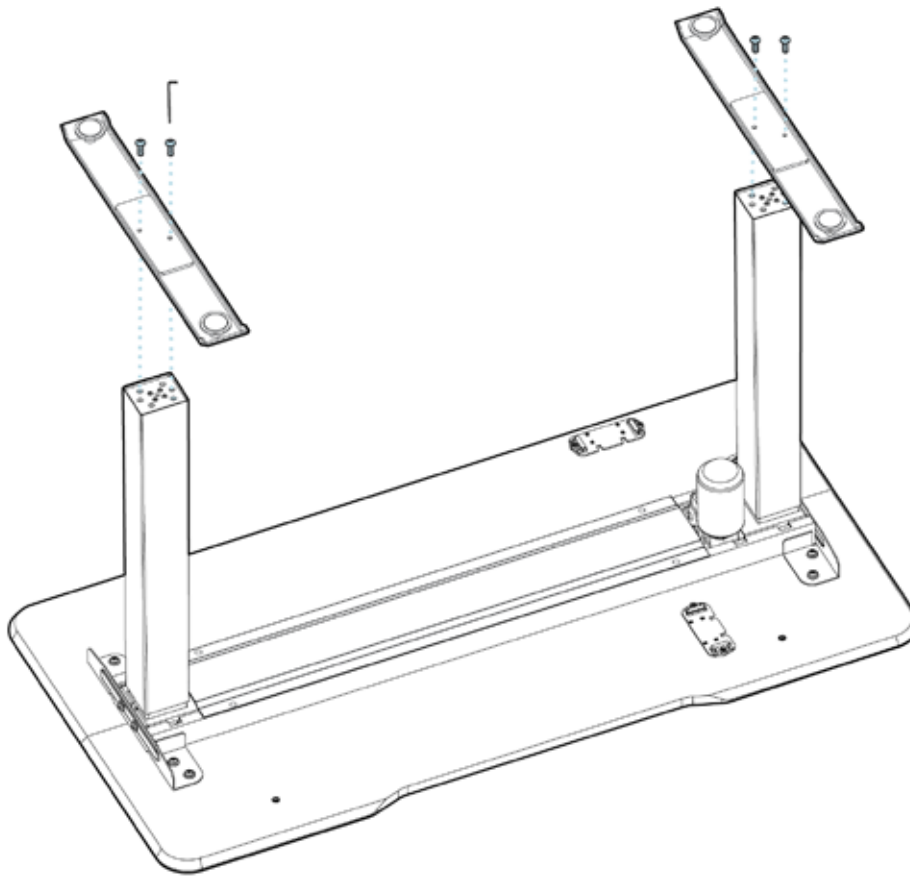

Using four (4) M10-25 bolts, turn the M10 Allen key clockwise to secure both feet to the legs.

16

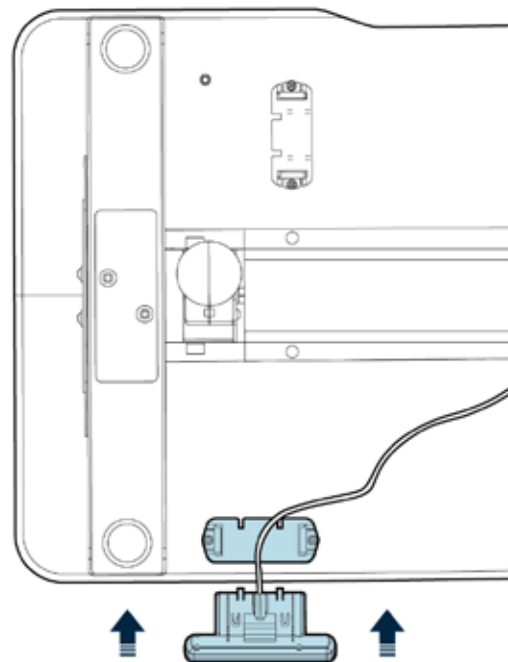

Locate the control panel bracket on the front edge of the desk (see the diagram on Step 2). Slide the control panel into the bracket.

17

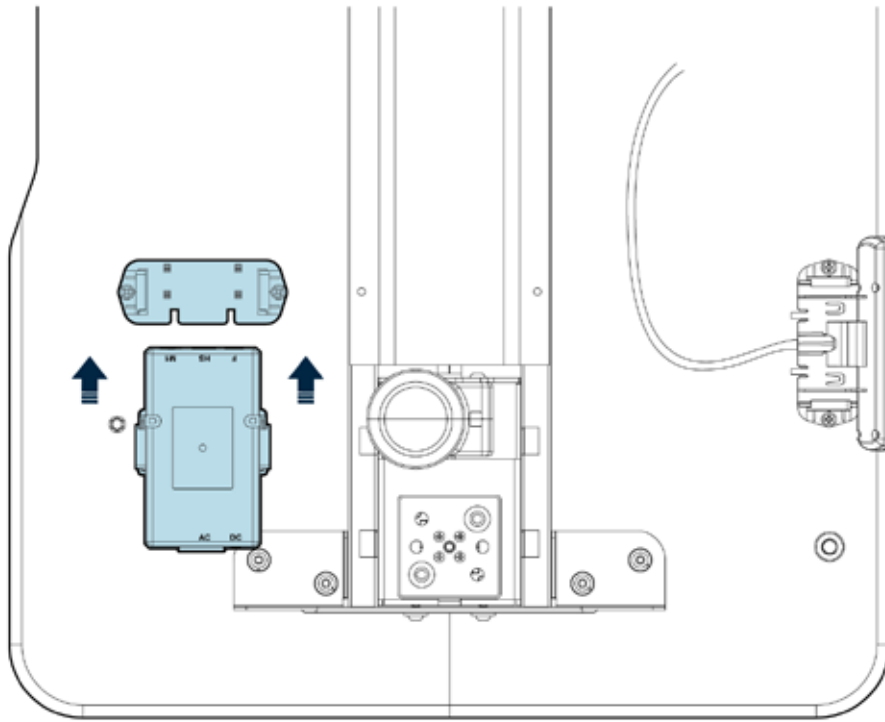

Locate the control box bracket (see the diagram on Step 2), and slide the control box into the bracket.

18

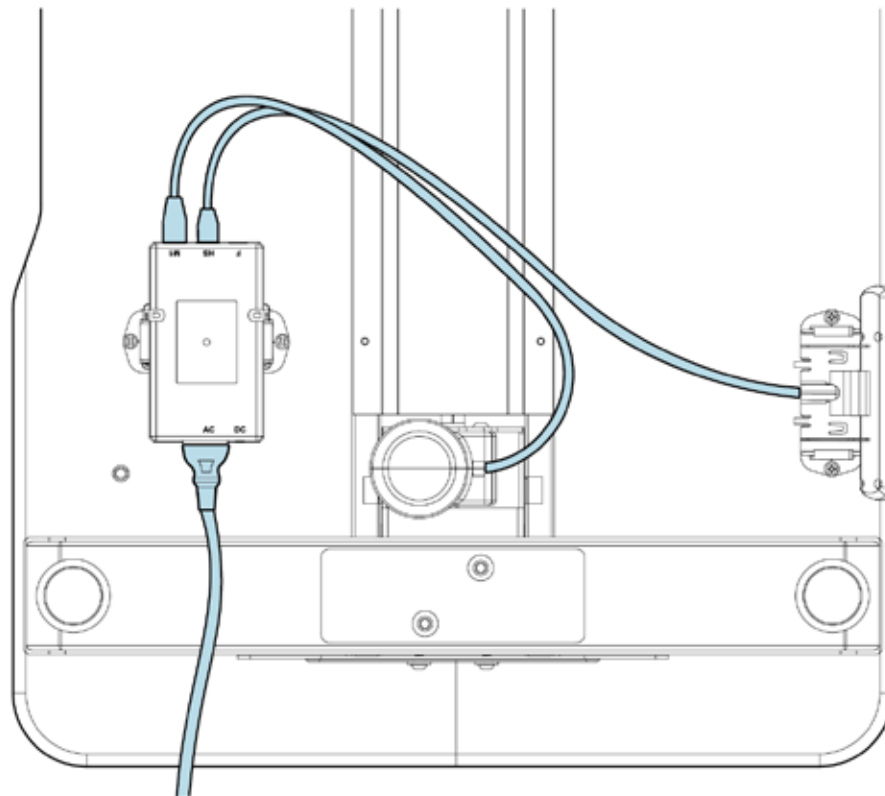

Connect the cord from the control panel into the slot on the control box labeled "HS". Next, connect the cord attached to the motor into the slot on the control box labeled "M1". Lastly, plug the power cord into the slot on the control box labeled "AC".

19

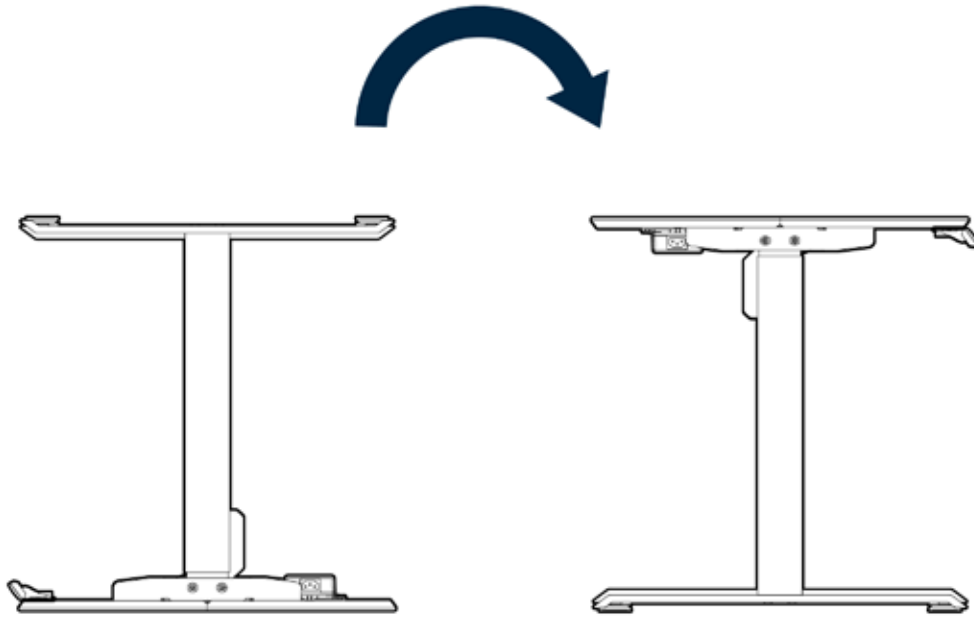

Using two people, lift and flip the desk over along the back edge, and set it down gently on its feet.

Connect to a power source. The desk is now ready to use.

Product Setup & Adjustments

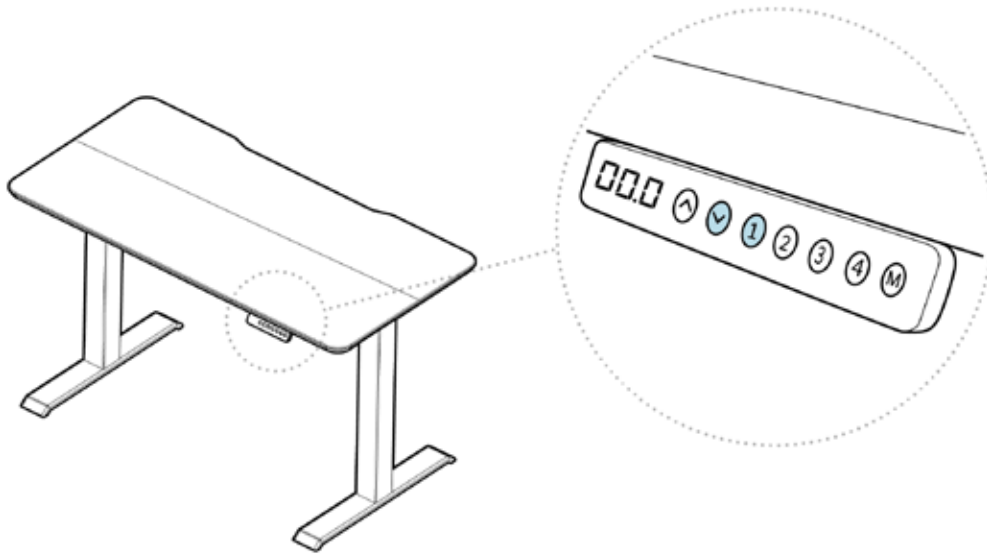

Initial Setup

Press the DOWN button on the control panel until the base reaches its lowest position. Press and hold the DOWN button again until the LED display reads “RST”.

Press and hold the 1 button (about 5 seconds) while the LED flashes “RST” and switches to either:

- 10.1 = One-Touch (preset buttons work with one quick press)
- 10.2 = Constant-Touch (preset buttons work when pressed and held down for a few seconds)

Release the 1 button. Press the 1 button again until desired setting is reached. Once the chosen setting is displayed, release the button and wait for the display to return to “RST”.

Finish the reset process by pressing and holding the DOWN button until the desk lowers a little bit more, slightly rises, and stops. Release the button. The new program is saved and your desk is now ready to use.

Inches to Centimeters

To toggle from inches to centimeters on the display, first press the DOWN button until the desk reaches the lowest position (27.5 inches). Press and hold the DOWN button again until the display flashes “RST”. Press and hold the 2 button (about 5 seconds) until the display flashes “RST” and then switches to either **10.3** (= cm) or **10.4** (= in).

If the display is not flashing “RST”:

1. Lower the desk to the lowest position (27.5 inches), then release the button.
2. Press and hold the DOWN button until the “RST” flashes and release the button.
3. Press and hold the DOWN button again until the display shows the height of 27.5 inches, then release the button.

If the display is already flashing “RST”, begin with step 2 above.

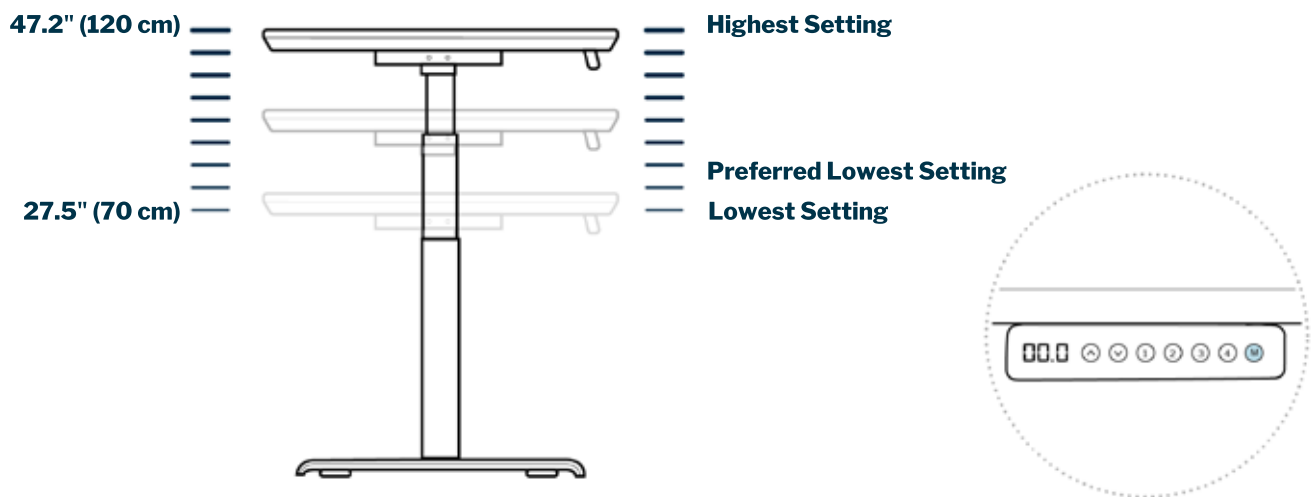

Height Settings and Preferences

The height settings range from 27.5 - 47.2 inches (70 - 120 cm). You can program 4 height preferences by raising or lowering the desk to your desired height, pressing the “M” button (you will see “S-” appear on the display), then pressing 1, 2, 3, or 4.

Setting Upper & Lower Limits

The height settings range from 27.5 - 47.2 inches (70 - 120 cm). If you prefer to change the settings to a more narrow range, follow the steps below.

Make sure the power is ON and a number reads on the LED display (if no number appears, please follow the Troubleshooting and Reset procedure).

To set the Upper-Limit Position: Use the UP/DOWN buttons to move the base to the desired maximum-height position. Press the “M” button and release. Press the UP button and release. The LED display will flash “S-”. Press and hold the “M” button until the LED display changes to “999”. The display will automatically return to the selected height. The new upper limit is now set.

To set the Lower-Limit Position: Use the UP/DOWN buttons to move the base to the desired minimum-height position. Press the “M” button and release. Press the DOWN button and release. The LED display will flash “S-”. Press and hold the “M” button until the LED display changes to “000”. The display will automatically return to the selected height. The new lower limit is now set.

To Remove Upper/Lower Limit Positions: Press the “M” button and release. The LED display will read “S-”. Within 5 seconds, press and hold the “M” button again for 2 seconds. The LED display will change to “555” and then automatically return to the height display. The upper and lower limits are now removed.

WARNING: A RESET procedure requires the desk base to fully retract (beyond any lower limit set). Please ensure that you have the proper clearance below the desk base.

After the upper and lower limits are set, the previous memory positions (1, 2, 3, 4) may be outside the new range of movement. If so, simply reset the memory positions.

If you attempt to revise a previously set upper or lower limit and it is outside of the existing range, you will need to remove the previously set upper/lower limits first.

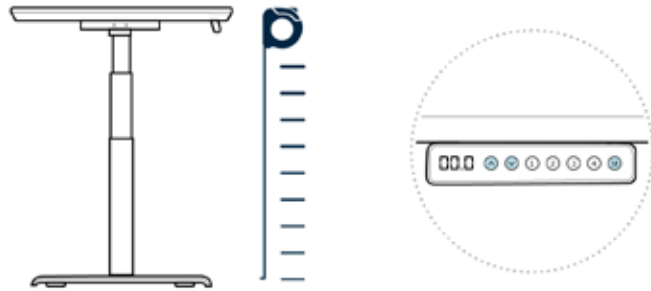

Recalibrating

The desk may need to be recalibrated if the screen is not showing the correct height—for instance the display reads 43 inches but is in fully lowered position. To do this, press the DOWN button on the control panel until the base reaches its lowest position. Measure the distance from floor to the top surface of the desktop. If the number on the LED display does NOT match your measurement, follow these steps:

Press and hold the DOWN button until the LED display reads “RST”. Press and hold the “M” button until the LED displays the flashing height. Use the UP/DOWN buttons to change the value of the starting height so that it matches your measurement. The display will return to “RST” in about 5 seconds.

Finish the reset process by pressing and holding the DOWN button again until the desk lowers a little bit more, slightly rises, and stops. Release the button. The new starting height value is saved and your desk is now ready to use.

NOTE: The LED display has a +/- 0.1 tolerance.

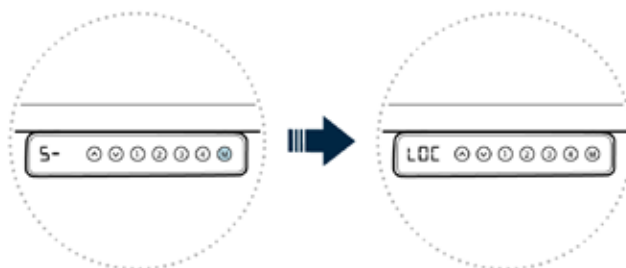

Control Panel Lock

Press and hold the “M” button (about 8 seconds) until the LED display switches to “S-” and then to “LOC”. Release the button.

Control Panel Unlock

Press and hold the “M” button (about 8 seconds) until the LED switches from “LOC” to the height display. Release the button.

Troubleshooting and Reset

If the legs have no response, your desk may need to be reset. Follow the initial setup instructions and ensure all connections are in the correct location and fully plugged in. If the legs are rising slowly, check the input power connection to make sure it's secured correctly. If any errors continue, please contact Vari.

CODE DESCRIPTION**TROUBLESHOOTING SOLUTION**

E01	Over Current Protection	Over current protection feature triggered, over current always caused by over loading. Remove items or reduce weight from concentrated area (rated loading is average distribution). Follow the reset instruction to reset the system. If error persists, contact Vari.
E07	Hall Error	E07 will display if the cable connected to the M1 port is not fully secured. Disconnect and reconnect the cable. Follow below instructions to reset (RST) the desk. If the error persists, contact Vari.
H01	Over Duty Protection	If the desk is raised and lowered continuously for more than 2 minutes, it will display this code and cease working temporarily to protect the mechanism from overheating. Stop adjusting the desk, and resume after 20 minutes.
RST RST	System Reset	<p>If the display is showing an ERROR CODE: Make sure all cables are securely connected. Press and hold the down button (about 5 seconds) on the control panel until RST flashes on the screen. Release the down button, and continue with the steps below.</p> <p>If the display is already flashing "RST": Press and hold the down button until the desk reaches the lowest height, raise slightly, and finally displaying height number. Do not release the down button until height number is shown on the control panel. The desk is now ready to use.</p>

**Supplier's Declaration of Conformity
47 CFR § 2.1077 Compliance Information**

Unique Identifier: 401512, 401513, 401514

Responsible Party – U.S. Contact Information

Varidesk, LLC
450 Freeport Parkway
Coppell, TX 75019
1-800-207-2587

FCC Compliance Statement

This device complies with Part 15 of the FCC Rules. Operation is subject to the following two conditions: (1) This device may not cause harmful interference, and (2) this device must accept any interference received, including interference that may cause undesired operation.



WARNING: Do not open any components; there is a danger of electric shock.



WARNING: Risk of electric shock. Connect this desk to a properly grounded outlet only.



WARNING: Keep plug away from heated surfaces.



WARNING: Risk of finger injury—pinching hazard. Use caution when folding and unfolding the desktop or when lowering desk.



CAUTION: Beverages such as water or coffee could cause product failure if spilled.



WARNING: To reduce risk of fire, electric shock, or personal injury, use only indoors and do not install in a wet or damp location.



WARNING: Never operate this product if it has a damaged cord or plug, if it is not working properly, if it has been dropped or damaged, or dropped into water. Contact our customer service department during business hours to report any issues. Our customer service team will provide a replacement if necessary.



WARNING: To avoid overheating, a protection program is built into the system limiting the legs from moving up and down continuously for more than 2 minutes within any 20 minute period. If the unit overheats, the display will show “H01” or “ERR”.



WARNING: Make sure no obstacles are in the desk’s path. Make sure the desktop is not touching any walls. Make sure all cords are appropriate length to accommodate the change in height.



CAUTION: Keep power cord away from heated surfaces and sharp edges. When the desk is not in use, store the cord underneath the desk.



CAUTION: Rotating transmission shaft can cause severe injury. Do not operate without transmission shaft cover properly installed, and keep hair and loose clothing away from shaft.

-
- This desk is only intended to be used as described in the instructions, in commercial and household settings. Do not use attachments not recommended by the manufacturer.
 - This desk has no user serviceable parts.
 - Unplug the desk from outlet before adding or removing any parts.
 - The desk edge should be at least 1" (2.5 cm) away from any surfaces or obstacles.

vari.



(800) 207-2587