

# Desk Shelf

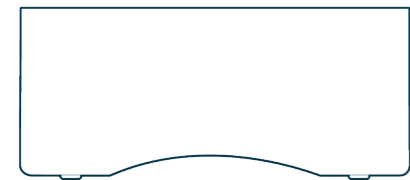

Holds up to  
50 lb (22.7 kg)

# vari®



SHELF LEG  
x3



4MM ALLEN KEY  
x1



M6 X 50MM SCREW  
x3



WOOD DOWEL PIN  
x6



WASHER  
x3

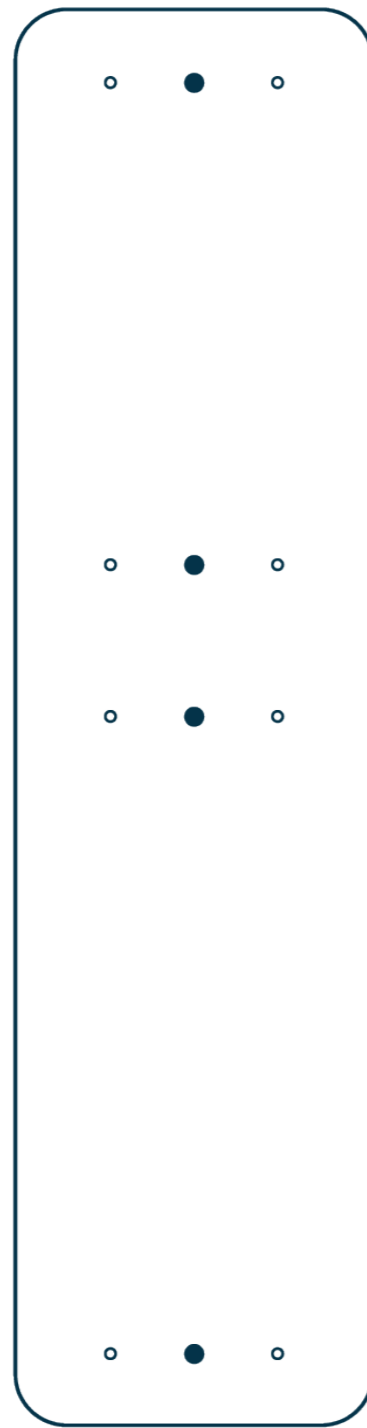
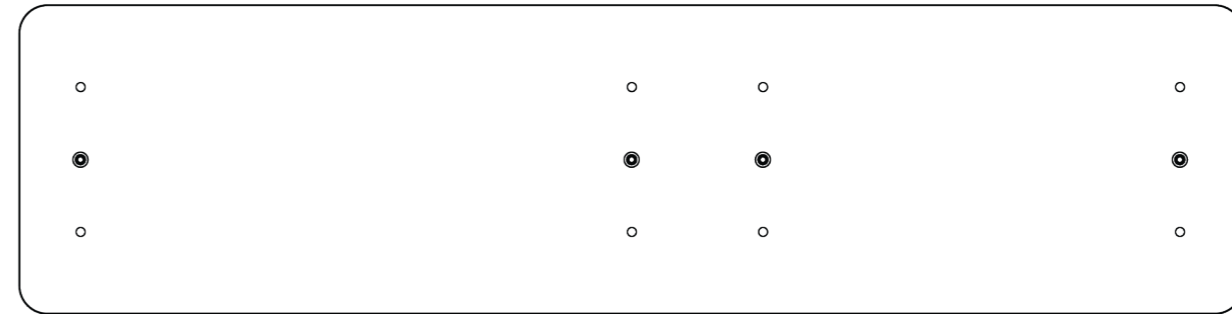

TABLE RISER TOP  
x1

1



Remove the Desk Shelf top from the box and lay it on a flat, smooth surface with the screw and dowel holes facing up.

2

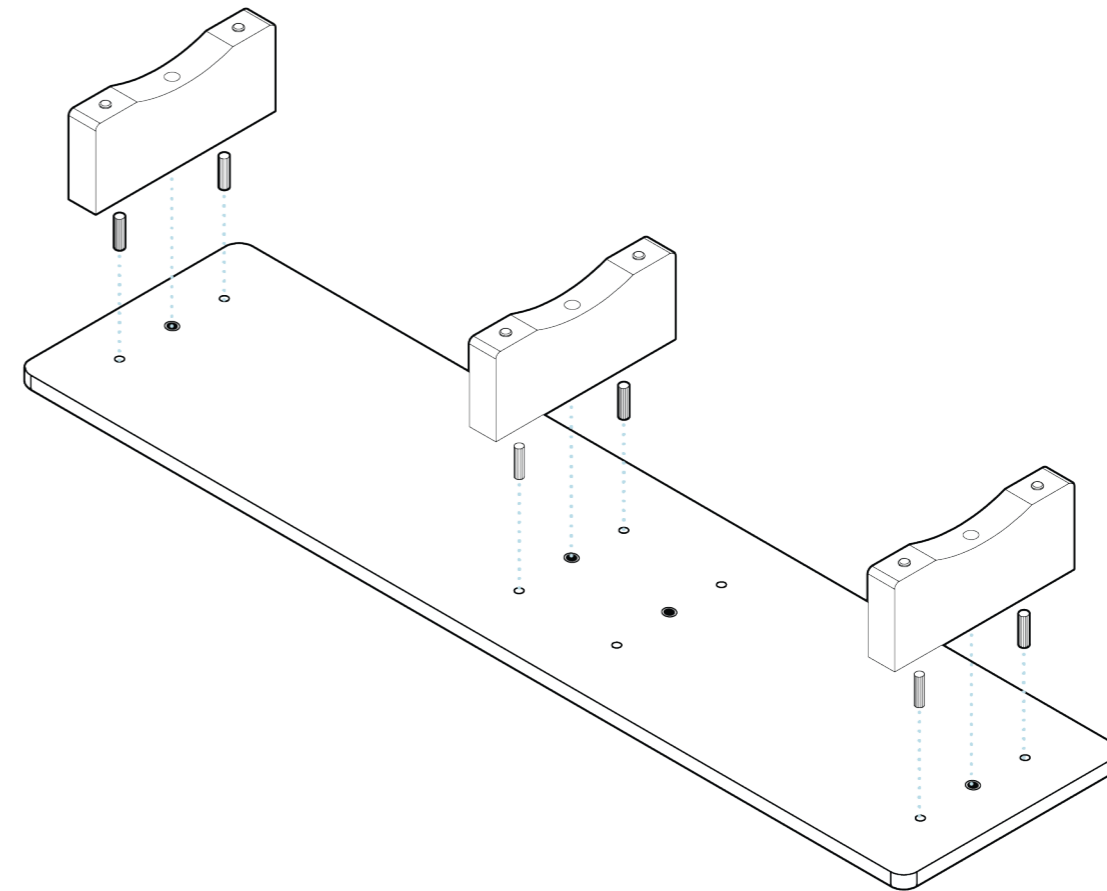

Insert the wood dowel pins into the outer holes.

3

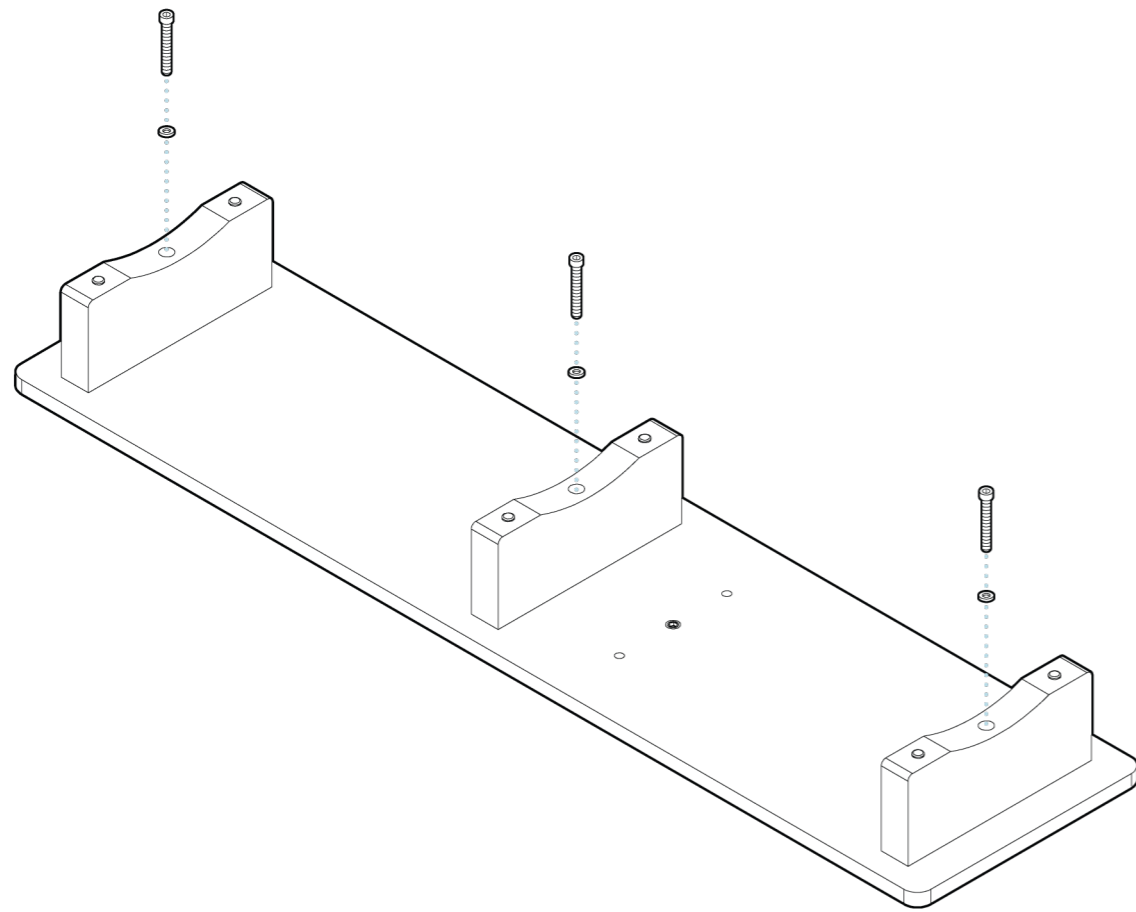

Place the washers on the screws and insert them into the center of the legs. Screw them in with the provided Allen key.

4

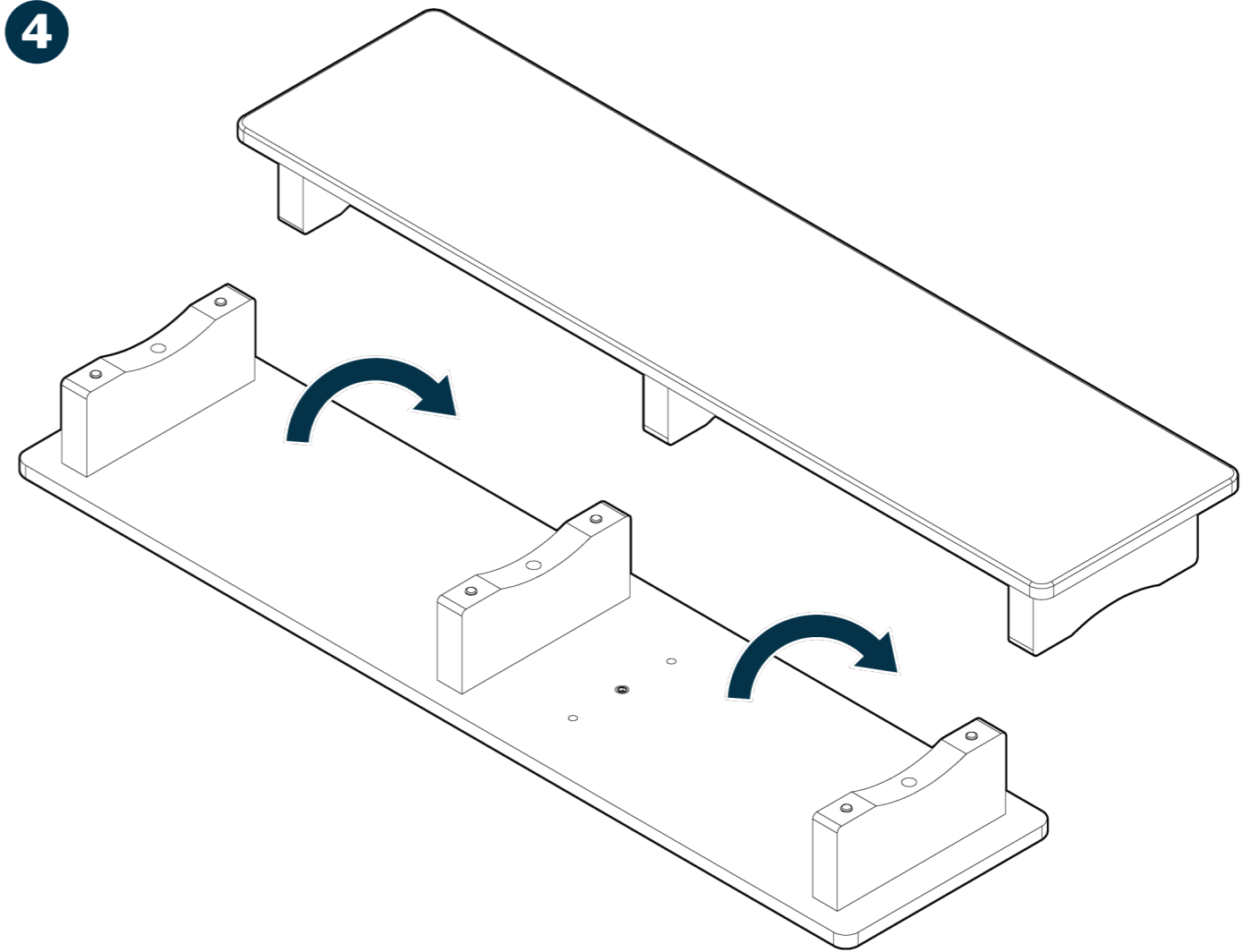

Turn the Desk Shelf over with the legs on the surface to complete the setup.



Do not attach monitor arms or other accessories to the Desk Shelf.

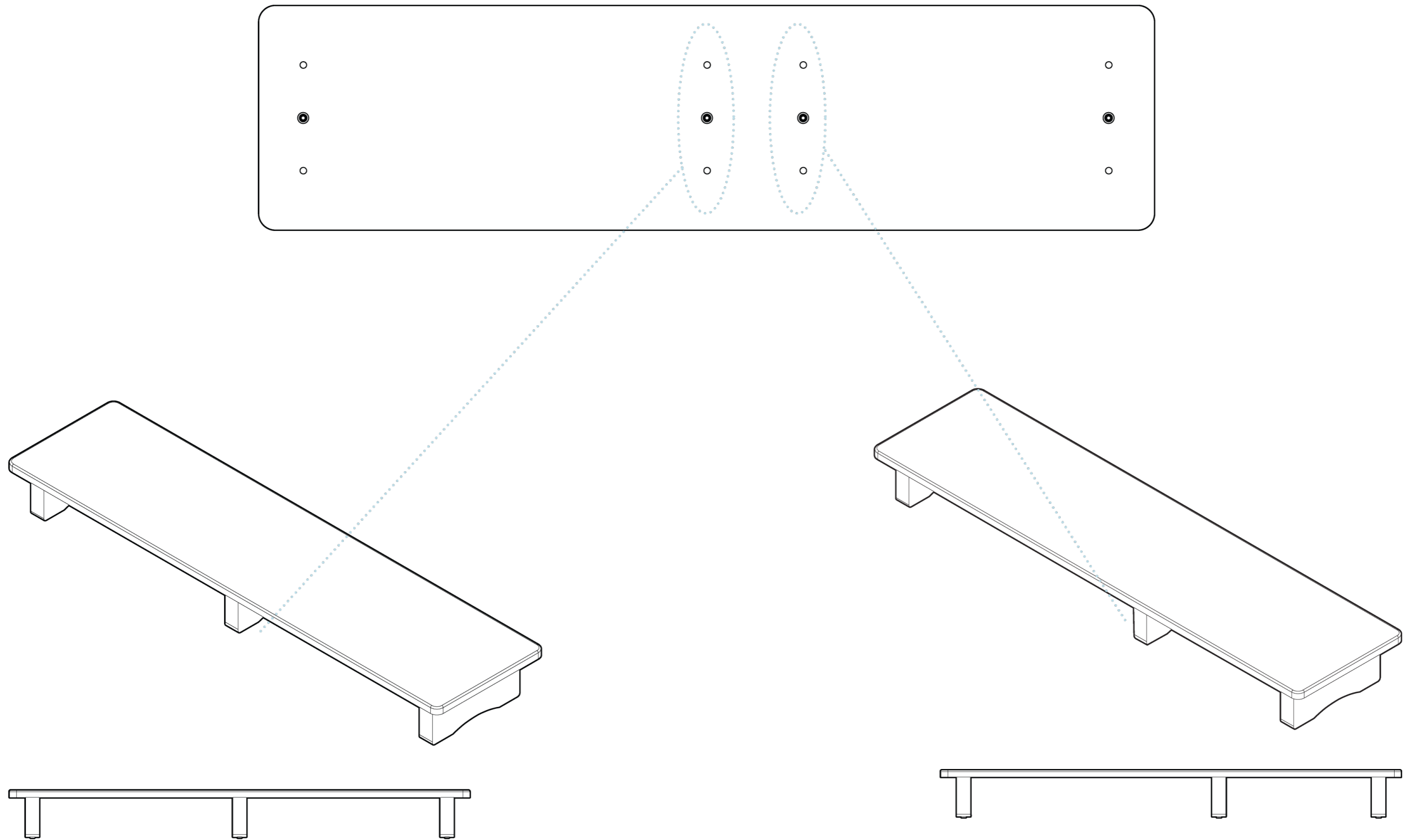

**Note:** The middle leg can be moved between the center and off-center positions to adapt to your devices and accessories.