

Contents

Weight Capacities and Warnings	3
Creating a Lower Credenza	4
Executive Bookshelf	5
Parts Needed If Joining with Other Pieces (Not Included)	5
Tools Needed (Not Included)	5
Adjusting the Leveling Feet	5
Joining Multiple Credenza Pieces Together	6
Adjusting the Shelf Placement	7
Executive Storage Cabinet	8
Parts Needed If Joining with Other Pieces (Not Included)	8
Tools Needed (Not Included)	8
Adjusting the Leveling Feet	8
Joining Multiple Credenza Pieces Together	9
Adjusting the Shelf Placement	10
Executive File Cabinet	12
Included Parts	12
Tools Needed (Not Included)	12
Adjusting the Leveling Feet	12
Parts Needed If Joining with Other Pieces (Not Included)	12
Joining Multiple Credenza Pieces Together	13
Adjusting the Drawer Pull Placement	14
Installing, Adjusting, and Removing File Hangers	15
Executive Lateral File Cabinet	16
Included Parts	16
Tools Needed (Not Included)	16
Adjusting the Leveling Feet	16
Parts Needed If Joining with Other Pieces (Not Included)	16
Joining Multiple Credenza Pieces Together	17
Adjusting the Drawer Pull Placement	18
Installing, Adjusting, and Removing File Hangers	19
Executive Wardrobe Cabinet	21
Included Parts	21
Tools Needed (Not Included)	21
Switching the Door Orientation	21
Adjusting the Shelf Placement	23
Joining the Executive Wardrobe Cabinet with Lower Credenza Pieces	25
Executive Overhead Cabinet	26
Parts Needed If Joining with Other Pieces (Not Included)	26
Tools Needed (Not Included)	26
Joining an Executive Overhead Cabinet with Executive Wardrobe Cabinets	26
Executive Desk	28
Included Parts	28
Tools Needed (Not Included)	28
Installing the Executive Desk Base and Lower Modesty Panel	29
Installing the Modesty Panel	34

Weight Capacities and Warnings

PRODUCT	TOP OF UNIT	ADJUSTABLE SHELF	BOTTOM SHELF
Executive Bookshelf	200 lb (91 kg)	76 lb (34.5 kg)	93 lb (42 kg)
Executive Storage Cabinet	200 lb (91 kg)	76 lb (34.5 kg)	93 lb (42 kg)

PRODUCT	TOP OF UNIT	TOP DRAWER	BOTTOM DRAWER
Executive File Cabinet	200 lb (91 kg)	16 lb (7.5 kg)	37 lb (17 kg)
Executive Lateral File Cabinet	200 lb (91 kg)	20 lb (9 kg)	87 lb (39.5 kg)

PRODUCT	OVERALL WEIGHT CAPACITY (TOP + INSIDE)
Executive Overhead Cabinet	70 lb (32 kg)

PRODUCT	TOP OF UNIT	ADJUSTABLE SHELF	BOTTOM SHELF	ROD
Executive Wardrobe Cabinet	55 lb (25 kg)	50 lb (22.5 kg)	50 lb (22.5 kg)	50 lb (22.5 kg)

 **WARNING:** The Executive Electric Standing Desk Modesty Panel 60" weighs 22 lb (10 kg). When adding it to your desk set up, do not exceed the Electric Standing Desk 60x30's weight limit of 200 lb (90.7 kg).

 **WARNING:** The Executive Electric Standing Desk Modesty Panel 72" weighs 28 lb (12.7 kg). When adding it to your desk set up, do not exceed the Electric Standing Desk 72x30's weight limit of 180 lb (81.6 kg).

 **WARNING:** Risk of finger injury—pinching hazard. Use caution when releasing and reconnecting cabinet door latches and when removing and reinstalling desk base panels.

 **WARNING:** Do not hang anything from the Executive Collection modesty panels.

Creating a Lower Credenza

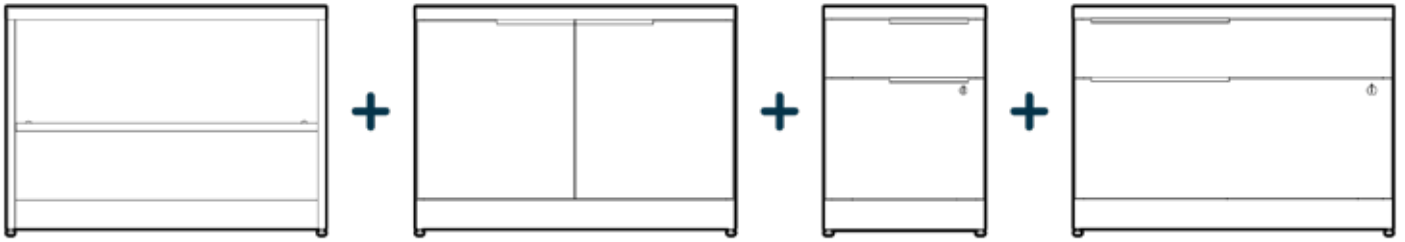

The Executive Collection contains four pieces that, in addition to working as stand-alone storage, can be mixed, matched, and joined together to create a credenza. See below for a few examples.

NOTE: Credenzas of joined cabinets should not exceed 96" wide. The lower credenza arrangement should be finalized before installing any upper cabinets (the Executive Wardrobe Cabinet and Executive Overhead Cabinet). Once upper cabinets are installed, attempts to remove those cabinets from the lower credenza may result in damage to the product. Joining bracket sets sold separately.

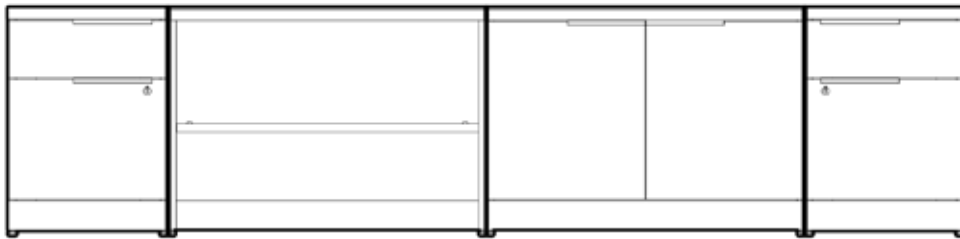

Executive File Cabinet, Executive Bookshelf, Executive Storage Cabinet, Executive File Cabinet



Executive Storage Cabinet, Executive Bookshelf, Executive Storage Cabinet

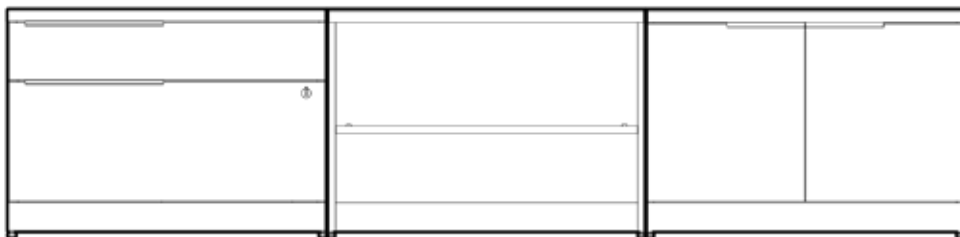

Executive Lateral File Cabinet, Executive Bookshelf, Executive Storage Cabinet

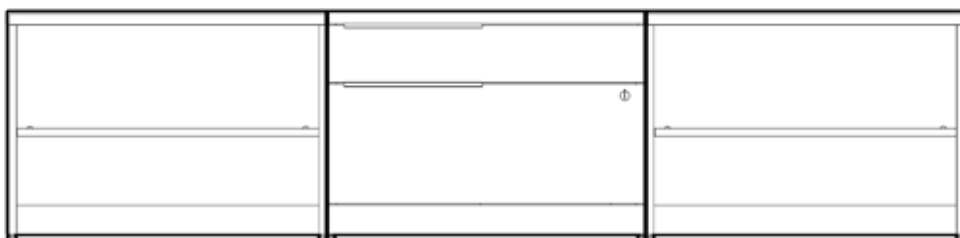

Executive Bookshelf, Executive Lateral File Cabinet, Executive Bookshelf

Executive Bookshelf

Parts Needed If Joining with Other Pieces (Not Included)

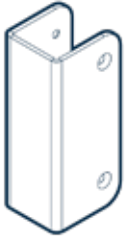

JOINING BRACKET
x2



$\frac{3}{4}$ " PHILLIPS DRIVE
WOOD SCREWS
x8

Tools Needed (Not Included)



PHILLIPS HEAD SCREWDRIVER
x1



$\frac{1}{2}$ " WRENCH
x1

Adjusting the Leveling Feet

1

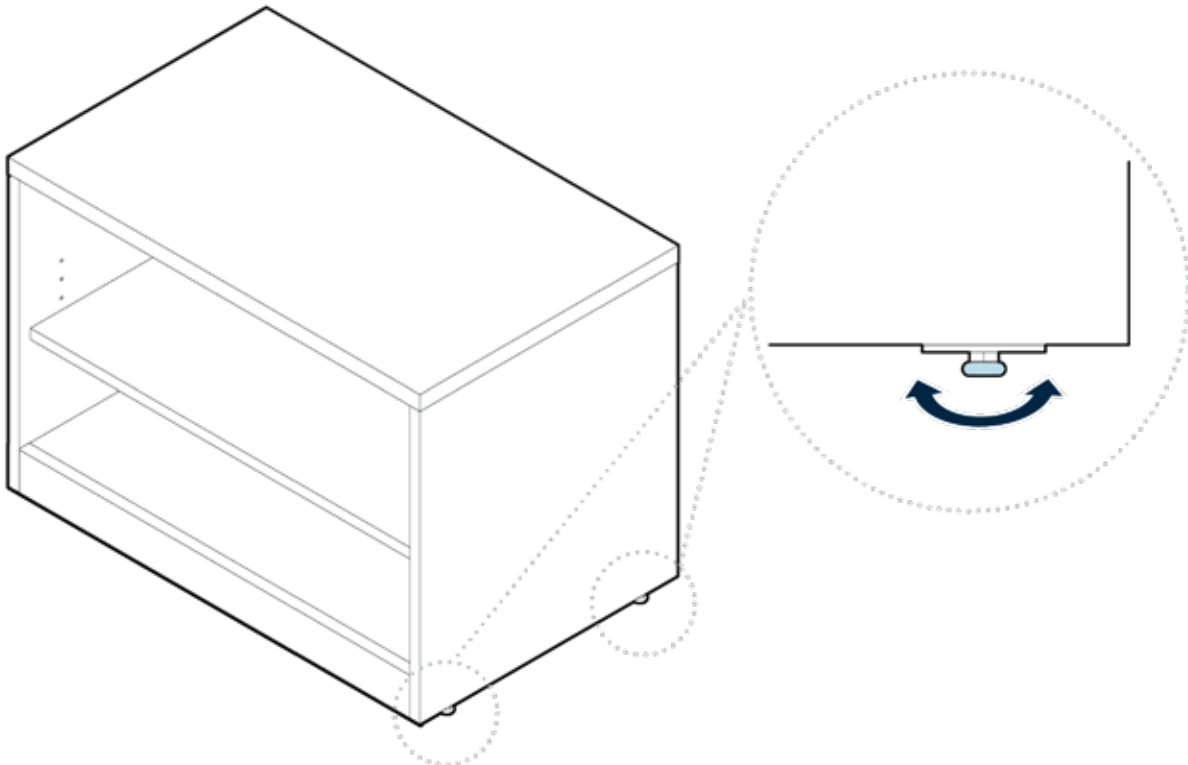

To adjust the leveling foot under each corner of the bookshelf, use a $\frac{1}{2}$ " wrench to twist each foot as needed. Turning the wrench clockwise lowers the foot, while turning the wrench counter-clockwise raises it.

Joining Multiple Credenza Pieces Together

1

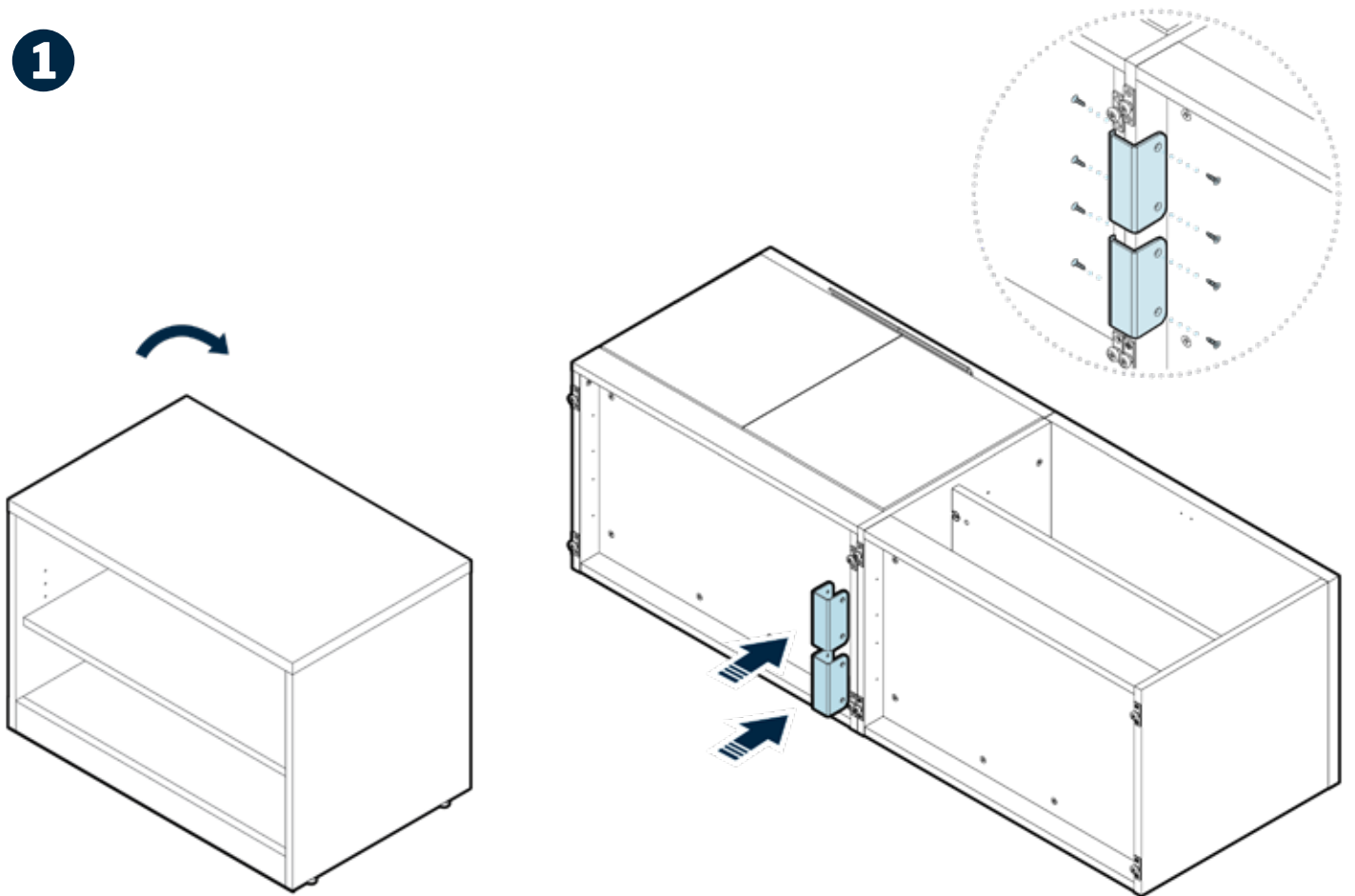

With assistance, tilt the empty bookshelf onto its back, and position it side-by-side with the other piece(s) of furniture. Slide two joining brackets over the adjacent side panel bases, aligning the holes in the brackets with the holes in the panels. Using a Phillips head screwdriver, secure each bracket with four wood screws.

2

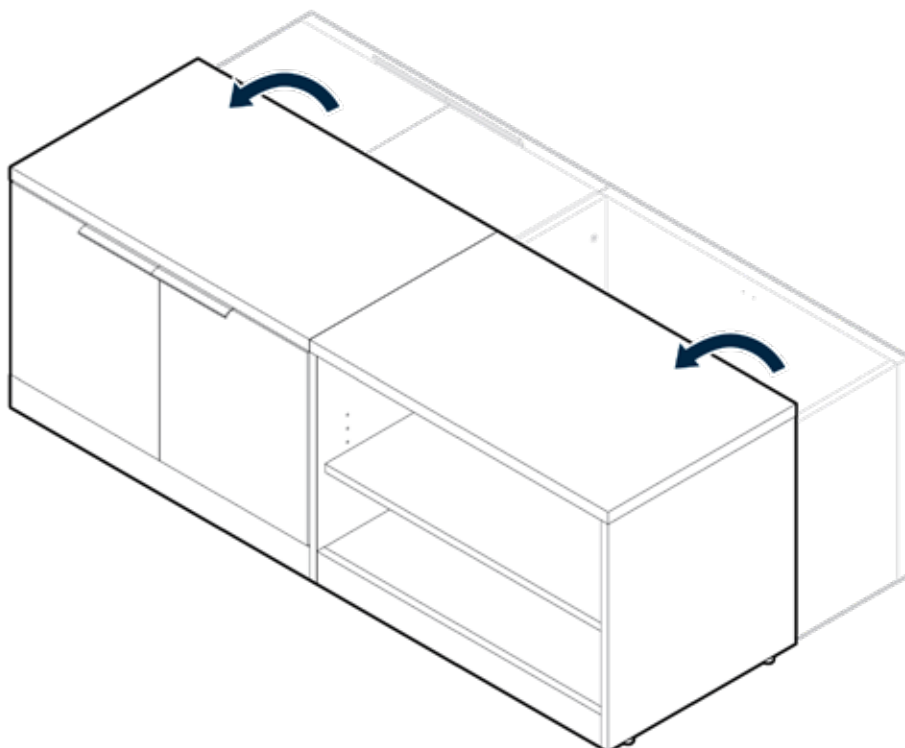

With assistance, tilt the joined pieces onto their feet. Use a ½" wrench to level as needed.

Adjusting the Shelf Placement

1

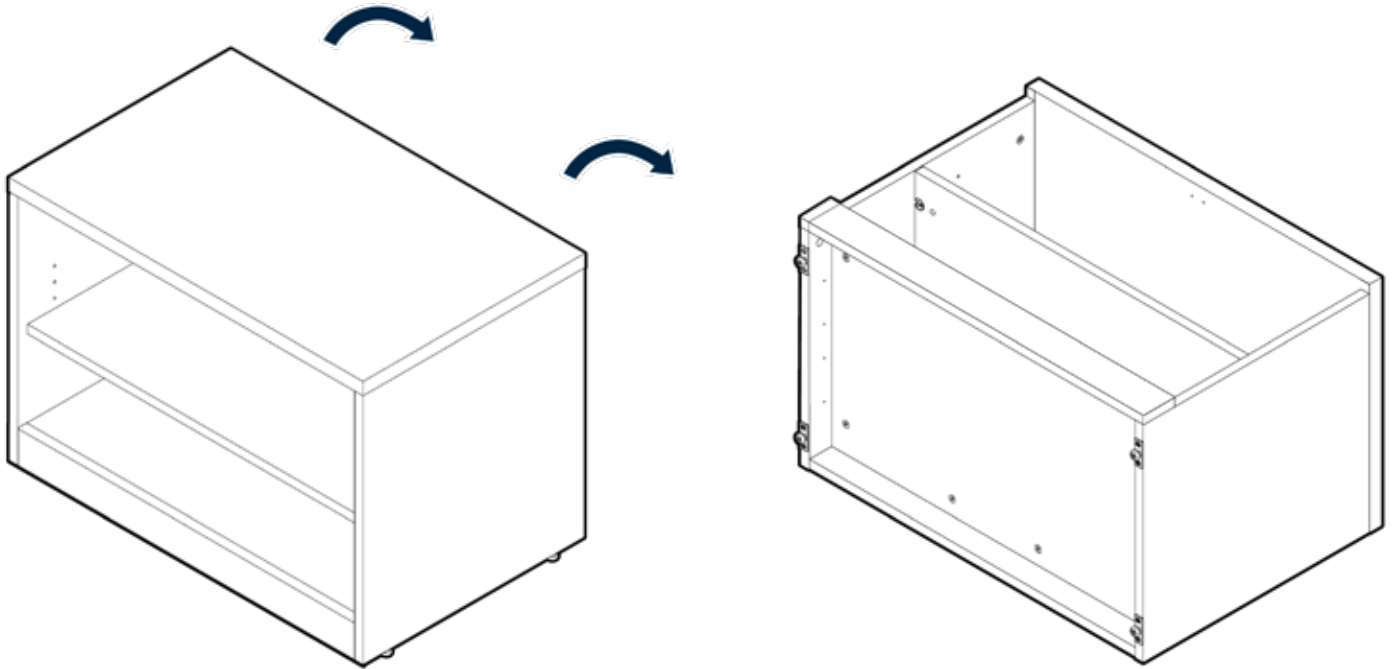

With assistance, tilt the empty bookshelf onto its back.

2

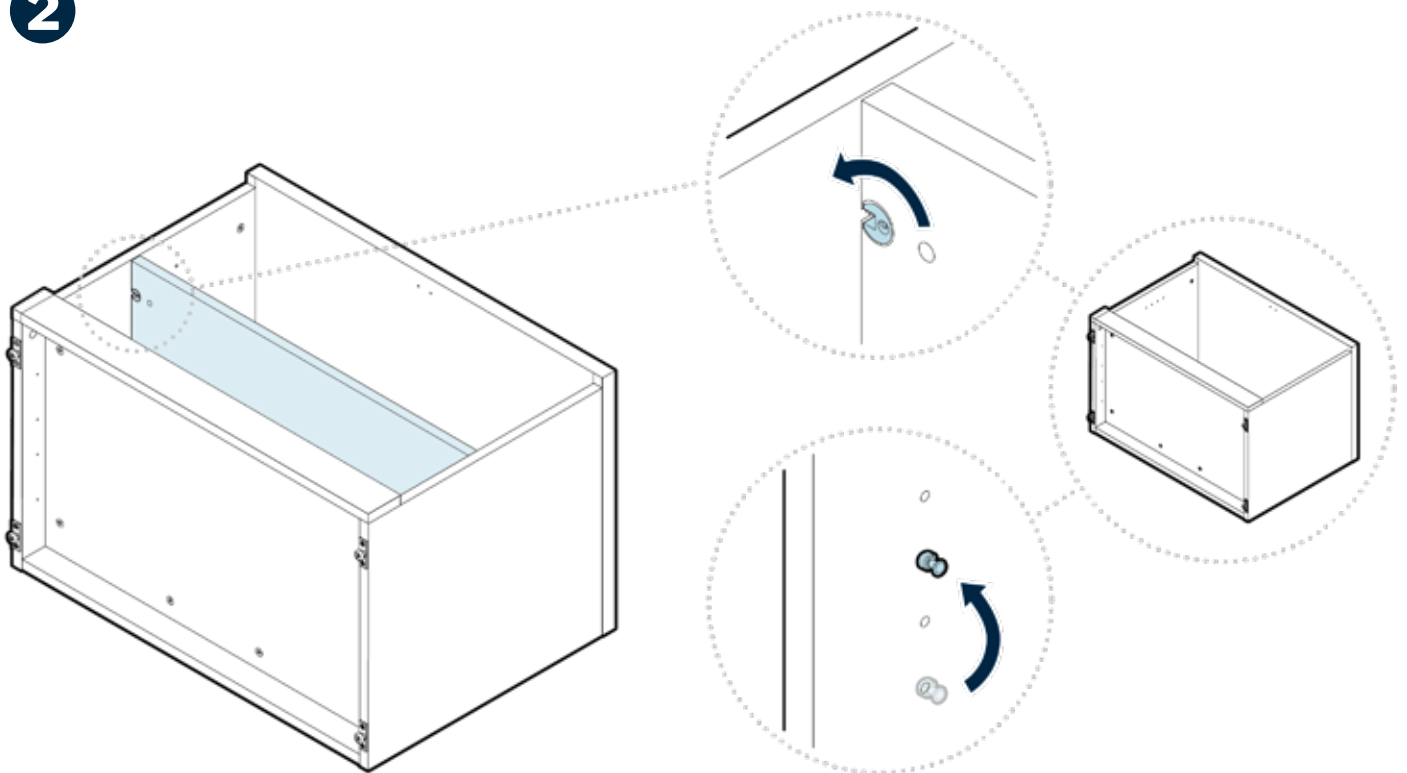

On the bottom of the shelf, there are 4 mini fix cams holding the shelf in place. To unlock the shelf, use a Phillips head screwdriver to turn the mini fix cams to the left. Remove the shelf, then move each peg to the desired position; all four pegs should be in the same position.

Return the shelf back to its place, aligning the mini fix cams with the repositioned pegs. To secure the shelf to the pegs, use a Phillips head screwdriver to turn the mini fix cams to the right until tight. Once the shelf is secure, tilt the bookshelf back on to its feet.

Executive Storage Cabinet

Parts Needed If Joining with Other Pieces (Not Included)

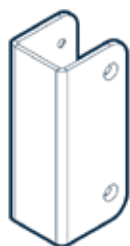

JOINING BRACKET
x2



3/4" PHILLIPS DRIVE
WOOD SCREWS
x8

Tools Needed (Not Included)



PHILLIPS HEAD SCREWDRIVER
x1



1/2" WRENCH
x1

Adjusting the Leveling Feet

1

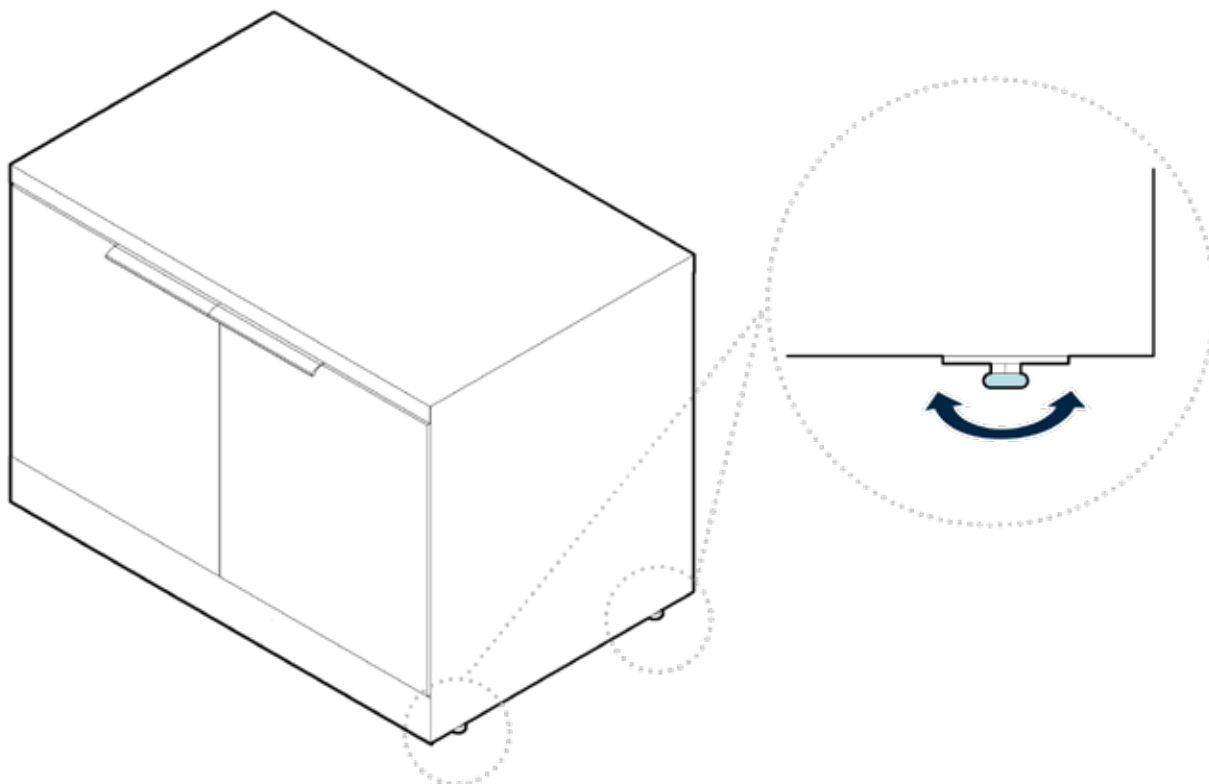

To adjust the leveling foot under each corner of the storage cabinet, use a 1/2" wrench to twist each foot as needed. Turning the wrench clockwise lowers the foot, while turning the wrench counter-clockwise raises it.

Joining Multiple Credenza Pieces Together

1

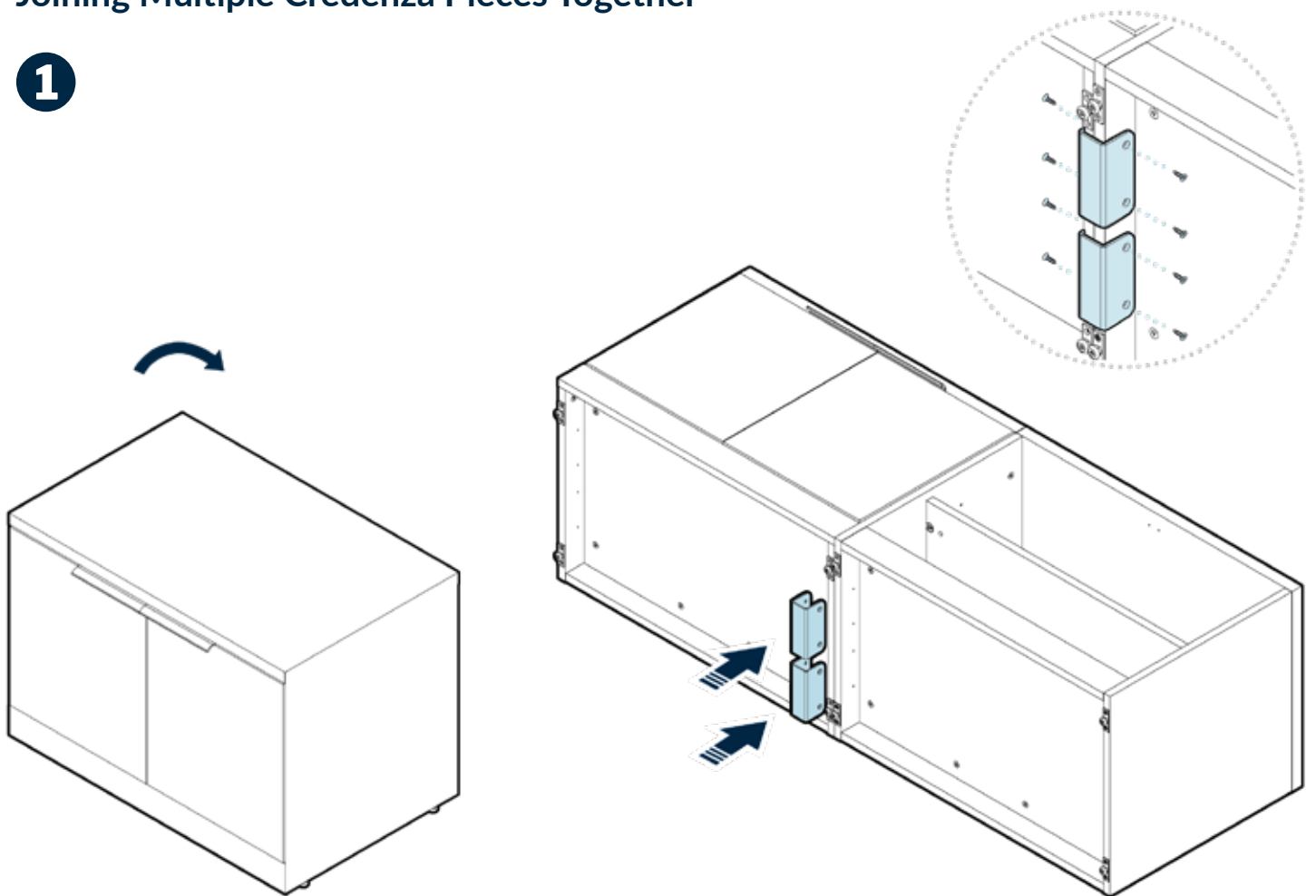

With assistance, tilt the empty storage cabinet onto its back, and position it side-by-side with the other piece(s) of furniture. Slide two joining brackets over the adjacent side panel bases, aligning the holes in the brackets with the holes in the panels. Using a Phillips head screwdriver, secure each bracket with four wood screws.

2

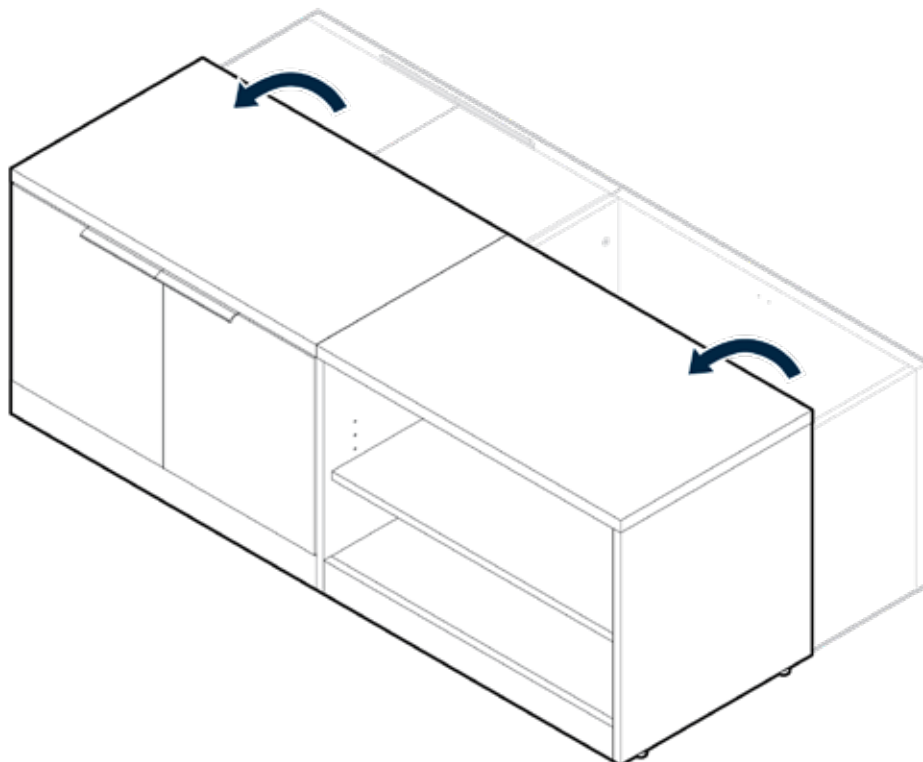

With assistance, tilt the joined pieces onto their feet. Use a ½" wrench to level as needed.

Adjusting the Shelf Placement

1

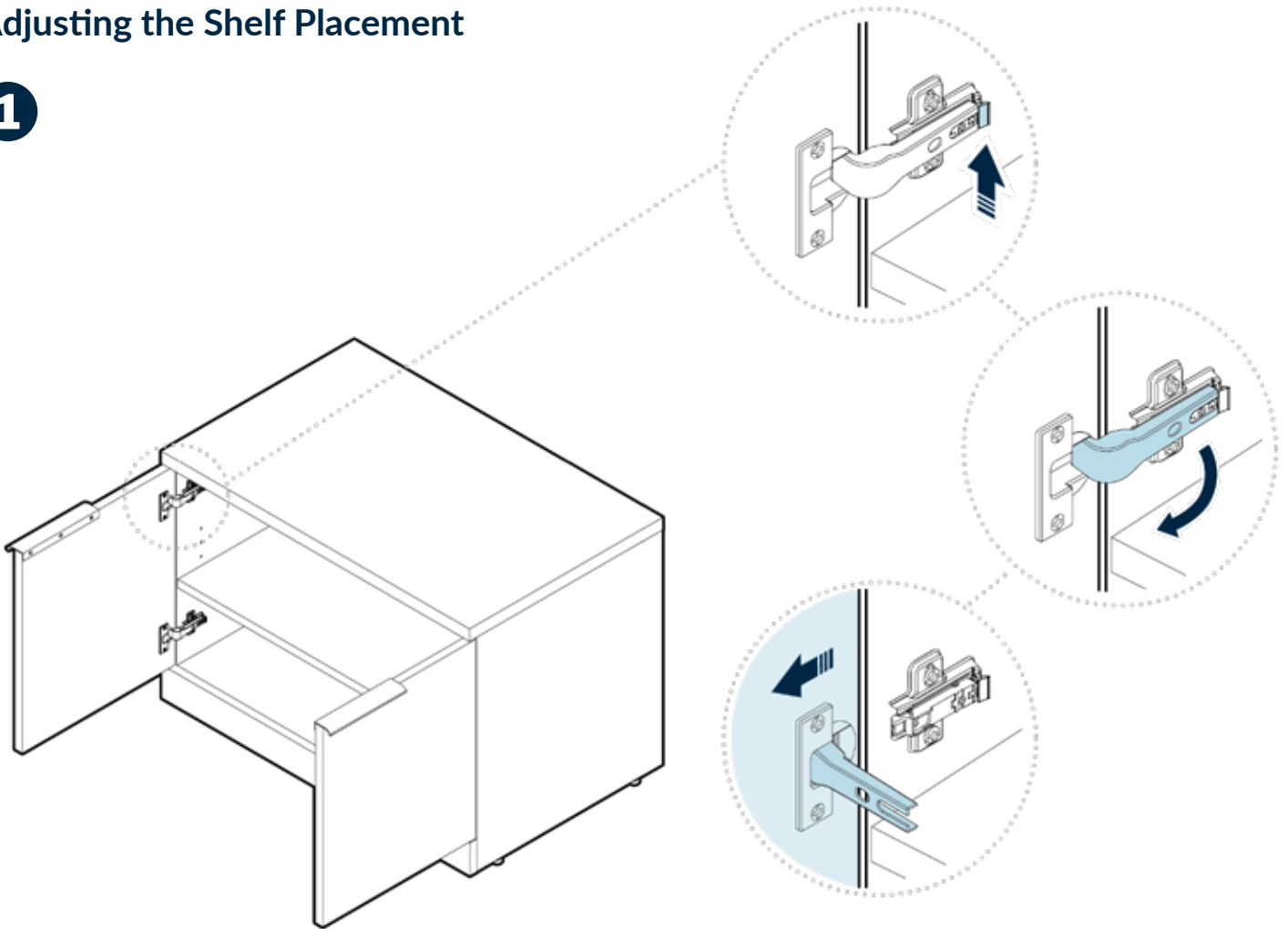

Open the storage cabinet doors. With one person holding an open door, another should remove the door by pressing the indicated lever to release the door glide, swinging the door glide out, and moving the door away from the cabinet. Repeat for the second door.

NOTE: Be careful not to pinch fingers!

2

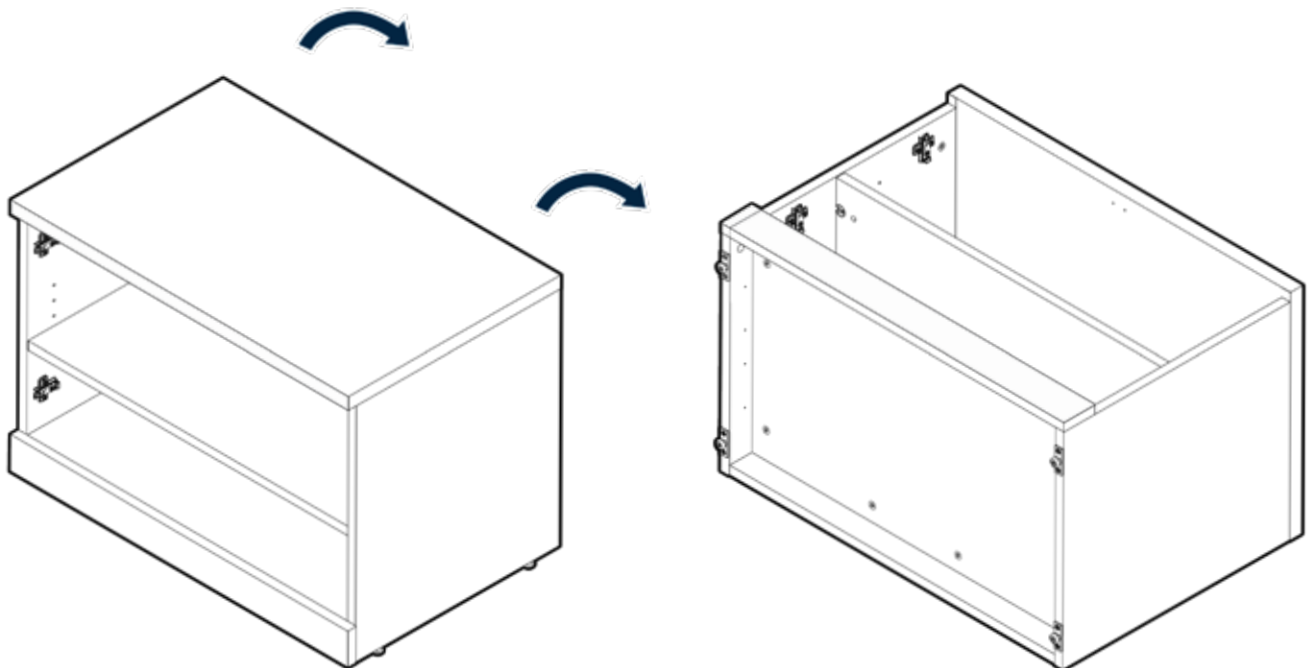

With assistance, tilt the empty storage cabinet onto its back.

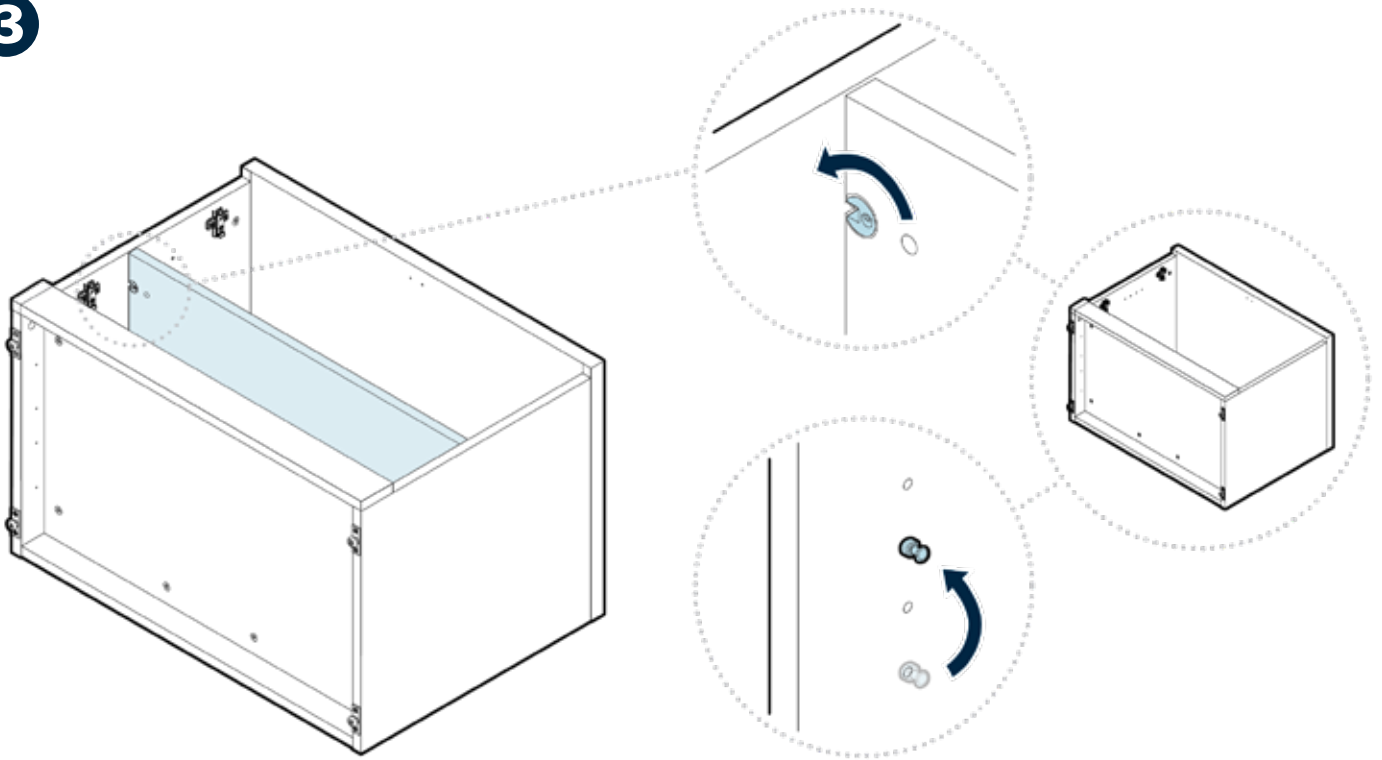
3

On the bottom of the shelf, there are 4 mini fix cams holding the shelf in place. To unlock the shelf, use a Phillips head screwdriver to turn the mini fix cams to the left. Remove the shelf, then move each peg to the desired position; all four pegs should be in the same position.

Return the shelf back to its place, aligning the mini fix cams with the repositioned pegs. To secure the shelf to the pegs, use a Phillips head screwdriver to turn the mini fix cams to the right until tight. With assistance, tilt the storage cabinet back onto its feet.

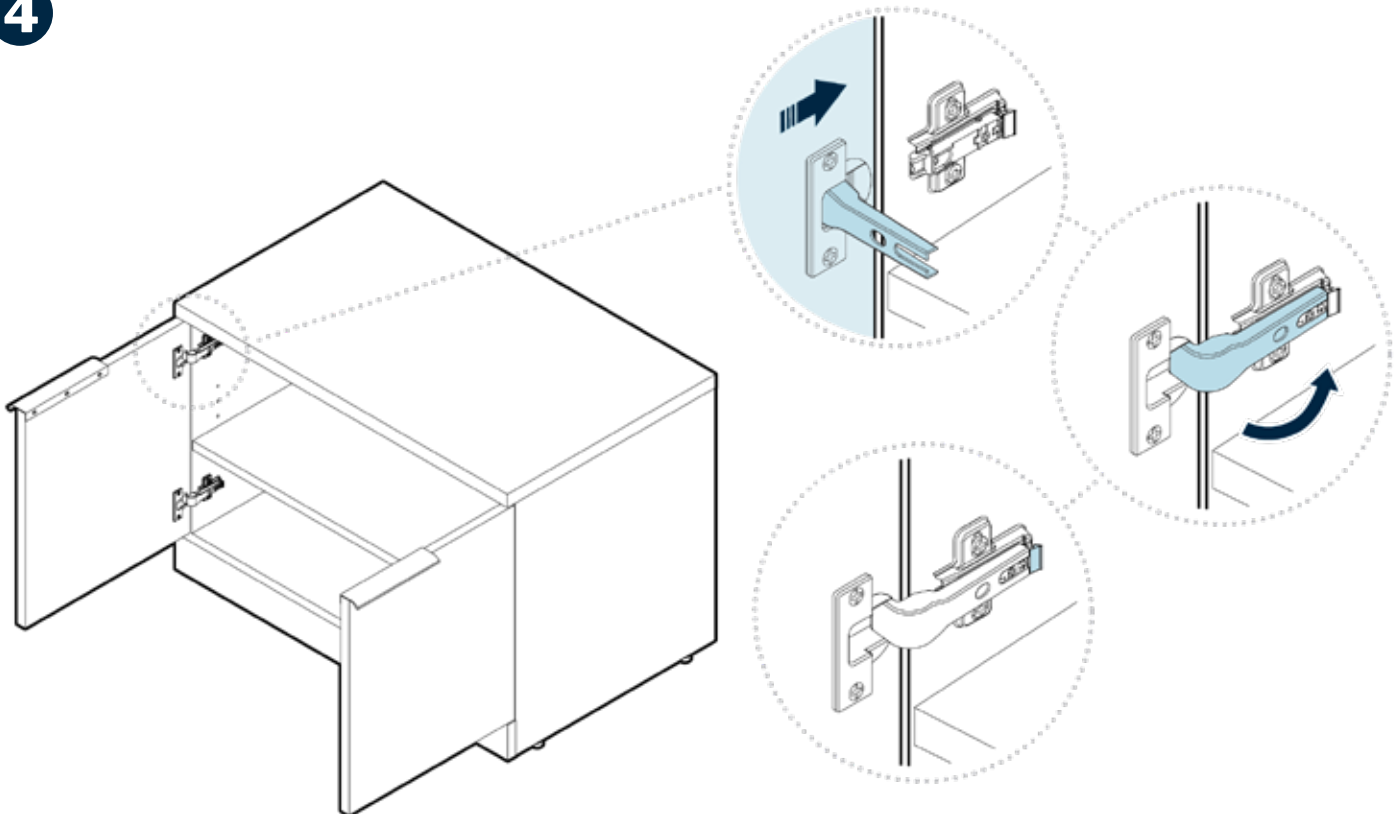
4

NOTE: Be careful not to pinch fingers! With one person holding a door in place, another person should reattach the door by swinging the door guide in, pressing the glide in place, and confirming the lever and guide are secure. Repeat for the second door.

Executive File Cabinet

Included Parts

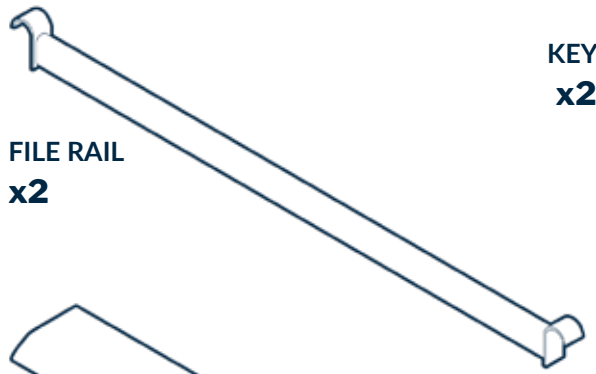

FILE RAIL
x2

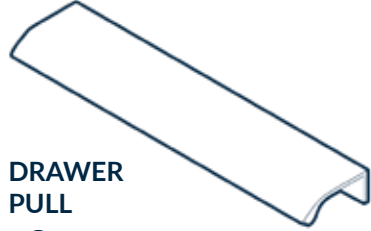

DRAWER PULL
x2

KEY
x2



3/4" PHILLIPS
DRIVE WOOD
SCREWS
x6



Parts Needed If Joining with Other Pieces (Not Included)



JOINING BRACKET
x2



3/4" PHILLIPS
DRIVE WOOD
SCREWS
x8

Tools Needed (Not Included)



1/2" WRENCH x1



PHILLIPS HEAD SCREWDRIVER x1

Adjusting the Leveling Feet

1

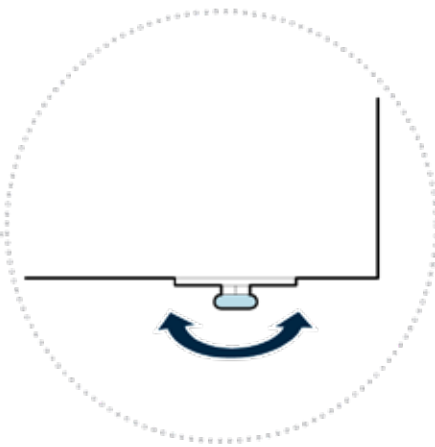
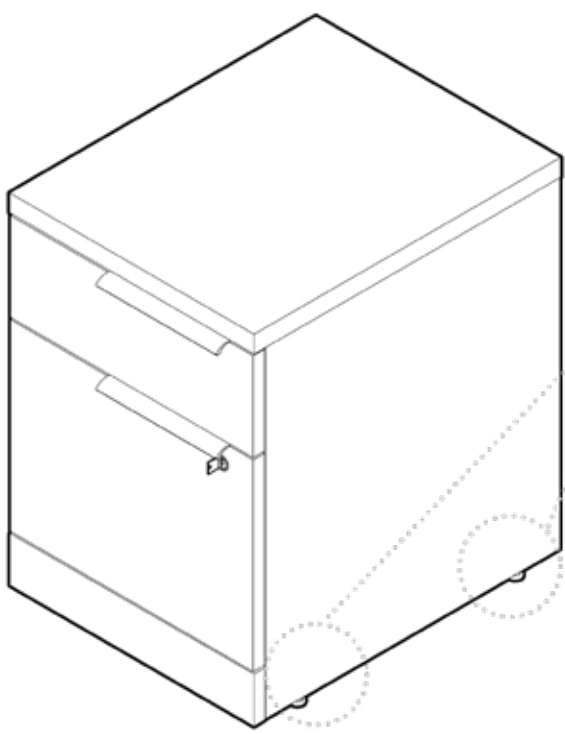

To adjust the leveling foot under each corner of the file cabinet, use a 1/2" wrench to twist each foot as needed. Turning the wrench clockwise lowers the foot, while turning the wrench counter-clockwise raises it.

Joining Multiple Credenza Pieces Together

1

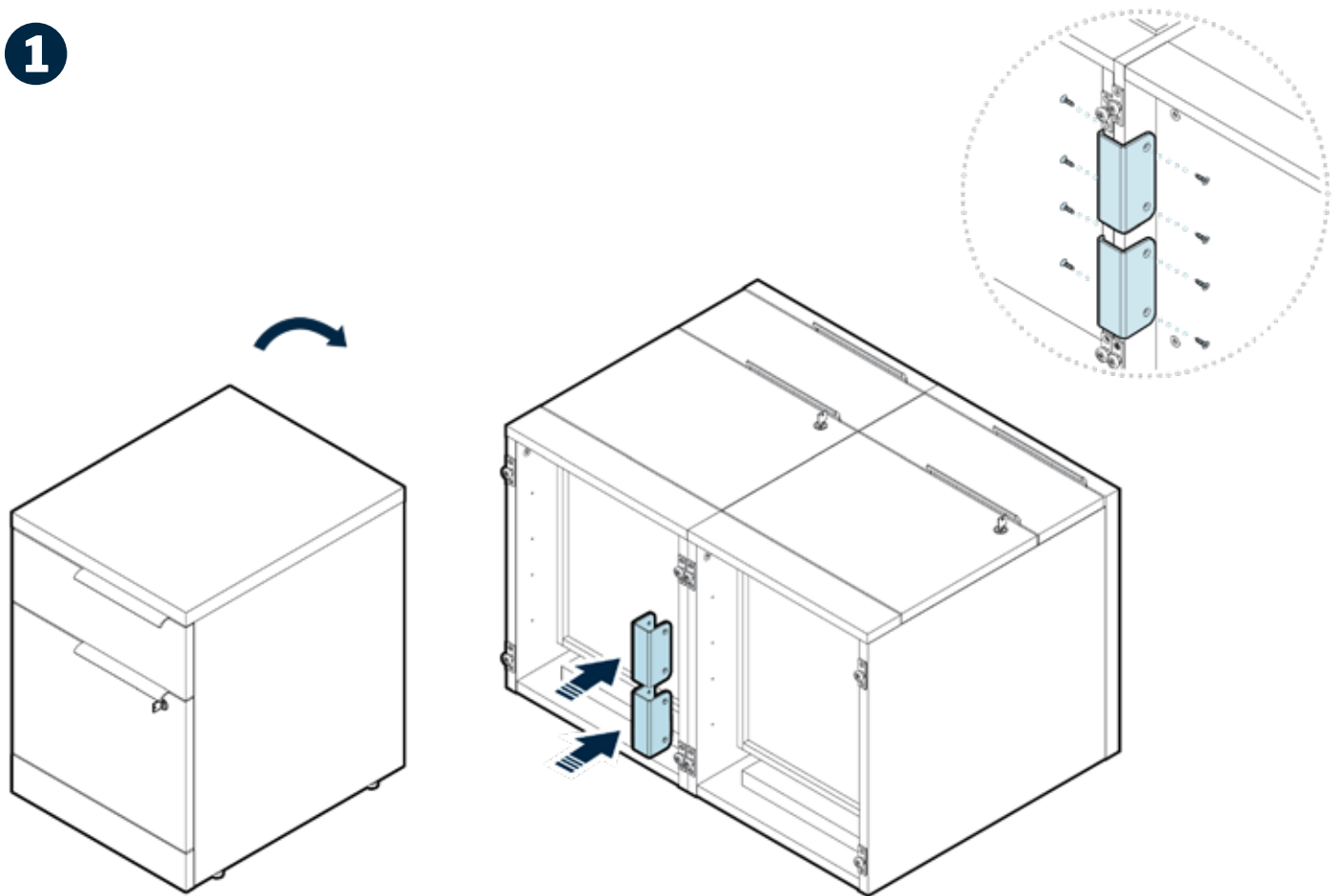

With assistance, tilt the empty file cabinet onto its back, and position it side-by-side with the other piece(s) of furniture. Slide two joining brackets over the adjacent side panel bases, aligning the holes in the brackets with the holes in the panels. Using a Phillips head screwdriver, secure each bracket with four wood screws.

2

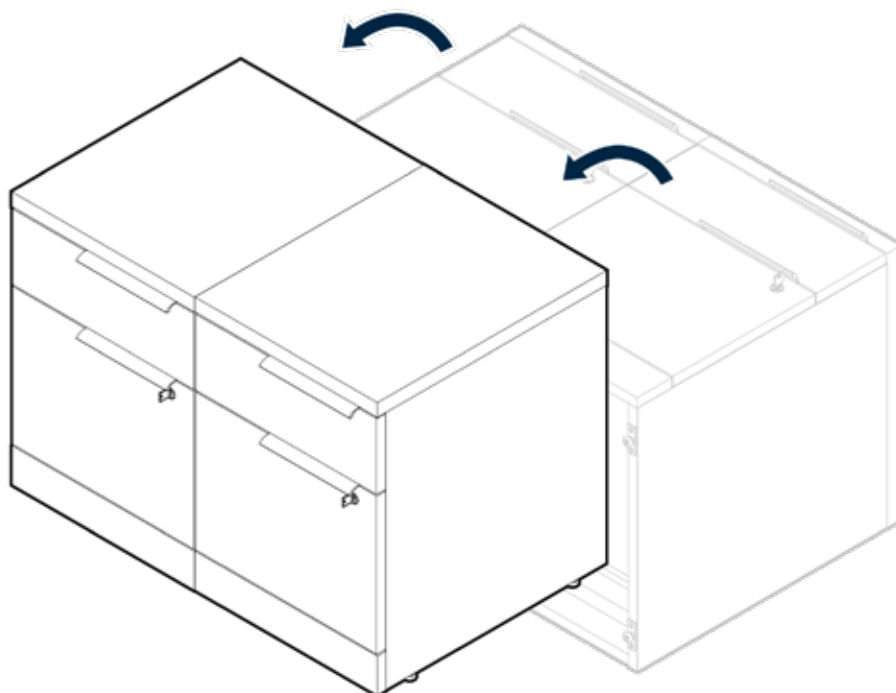

With assistance, tilt the joined pieces onto their feet. Use a $\frac{1}{2}$ " wrench to level as needed.

Adjusting the Drawer Pull Placement

1

LEFT ALIGN

Left hole on drawer pull aligns to left hole on drawer.

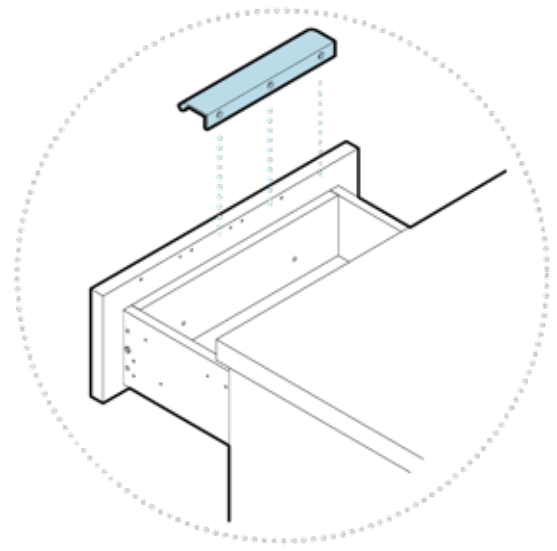

CENTERED

Center hole on drawer pull aligns to center hole on drawer.

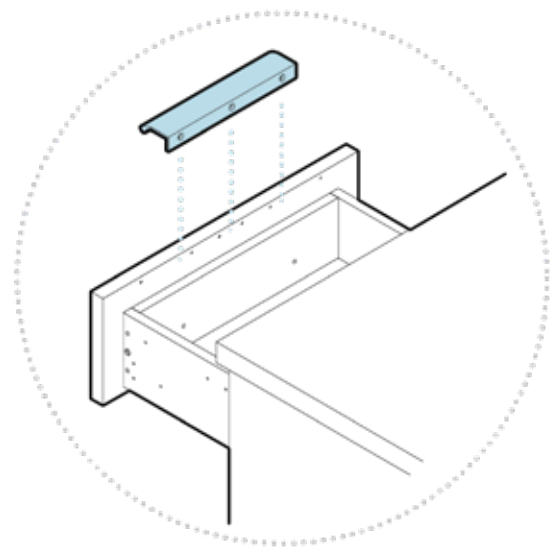

RIGHT ALIGN

Right hole on drawer pull aligns to right hole on drawer.

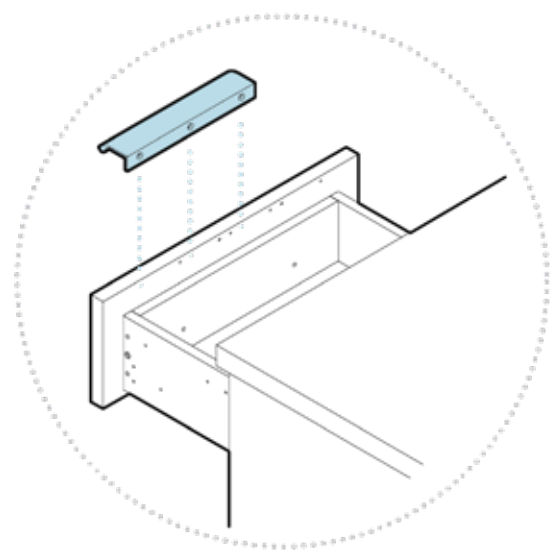

To install the drawer handles, align either the left, center, or right hole on the drawer pull to the predrilled left, center, or right hole on the file cabinet drawer. Secure the drawer pull with 3 wood screws and a Phillips head screwdriver. Repeat for the second drawer.

Installing, Adjusting, and Removing File Hangers

1

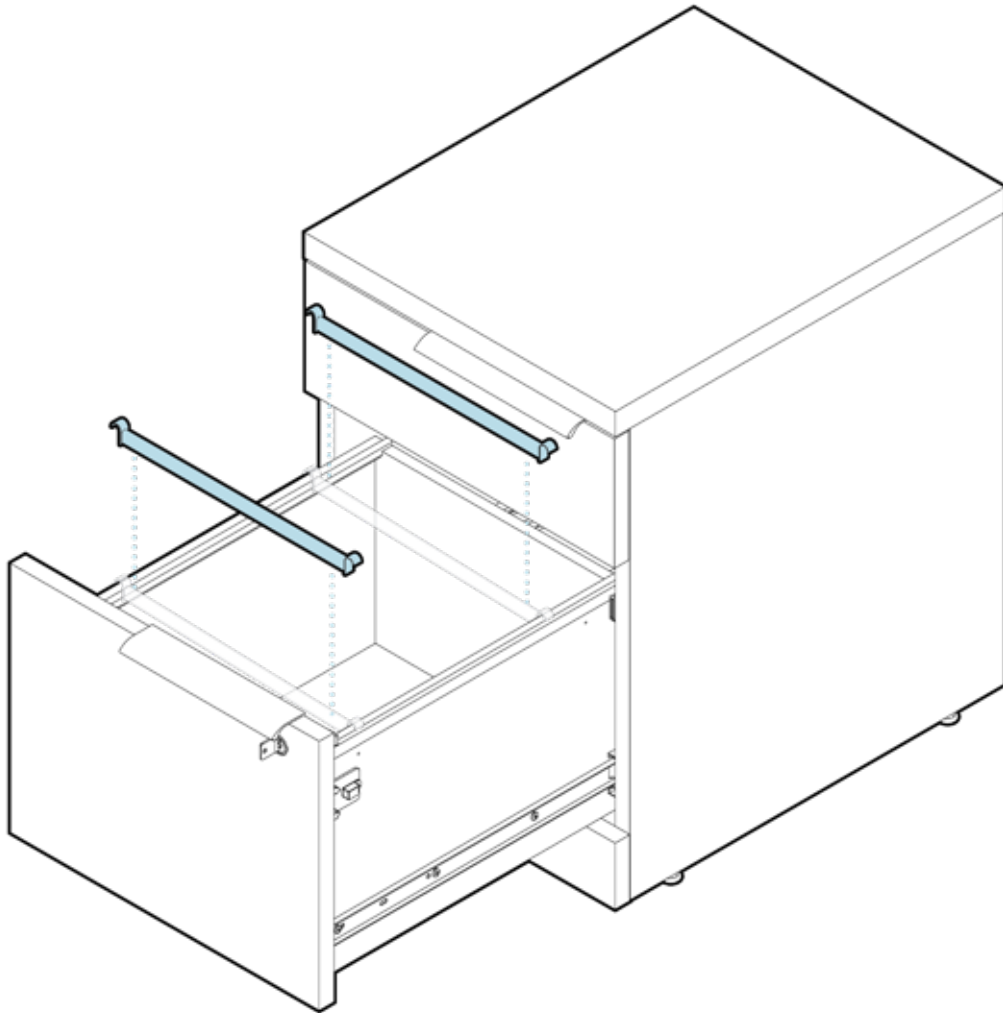

To install the file rails, simply place them on the side tracks of the bottom drawer. To reposition or remove the file rails, press along the bottom of the side track near the file rail to release the locking tooth, then slide the rail into the desired position or lift the rail off the tracks to remove.

2

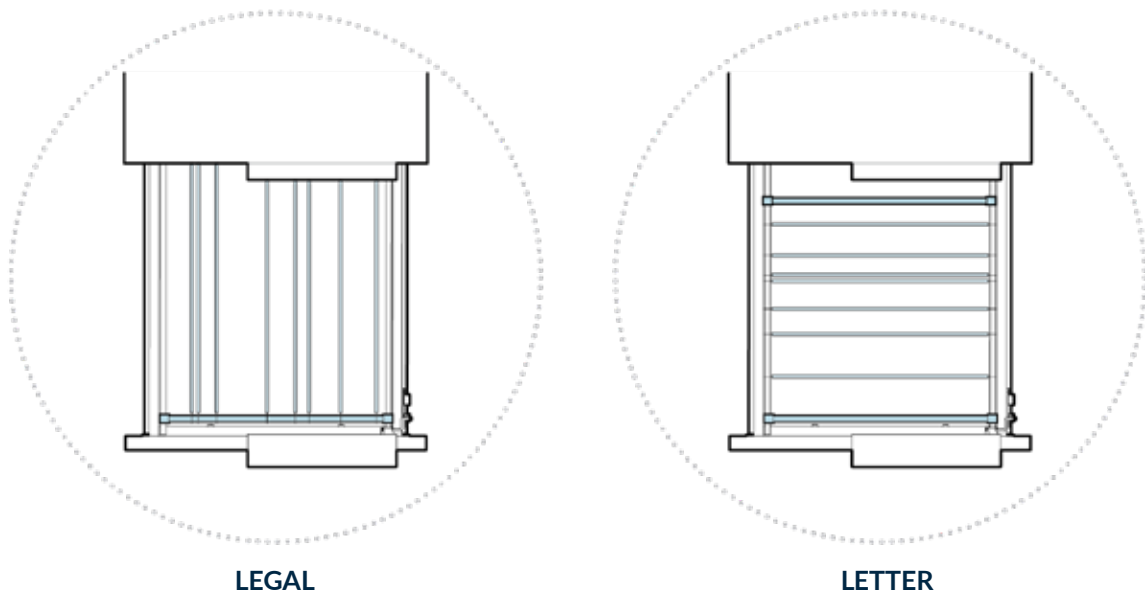

Legal files will hang front-to-back from the file rails. Most other files, including letter files, will hang side-to-side from the tracks; the rails can be used to separate files from each other or other contents of the drawer.

Executive Lateral File Cabinet

Included Parts

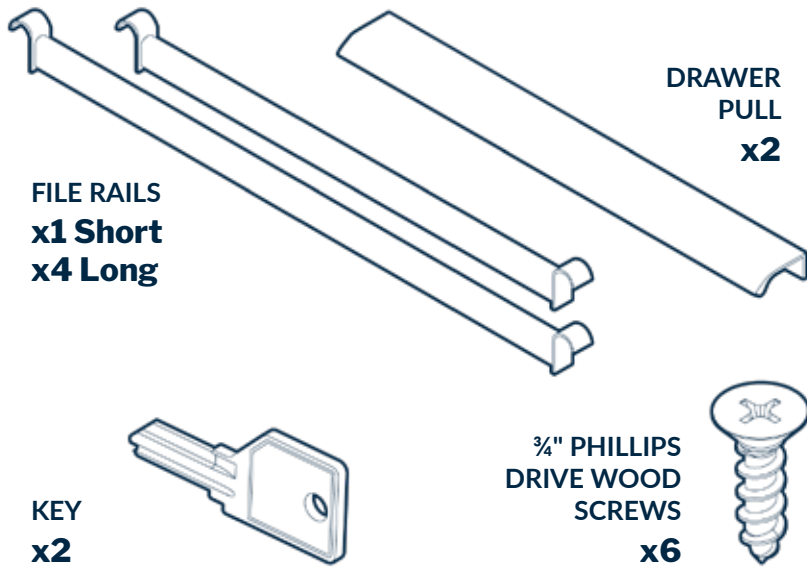

Parts Needed If Joining with Other Pieces (Not Included)

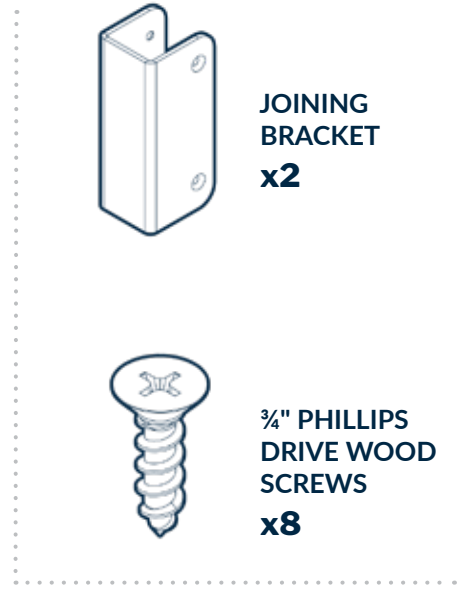

Tools Needed (Not Included)



Adjusting the Leveling Feet

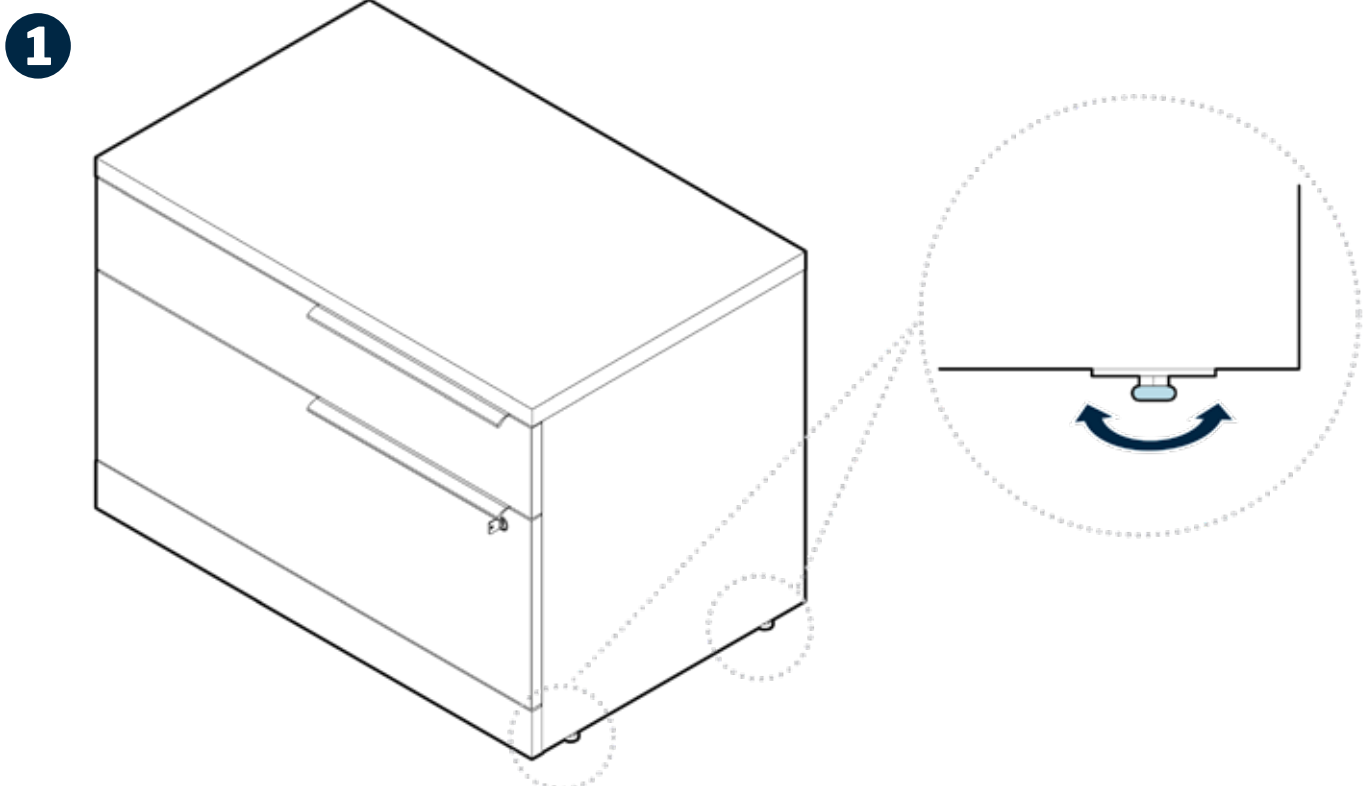

To adjust the leveling foot under each corner of the lateral file cabinet, use a $\frac{1}{2}$ " wrench to twist each foot as needed. Turning the wrench clockwise lowers the foot, while turning the wrench counter-clockwise raises it.

Joining Multiple Credenza Pieces Together

1

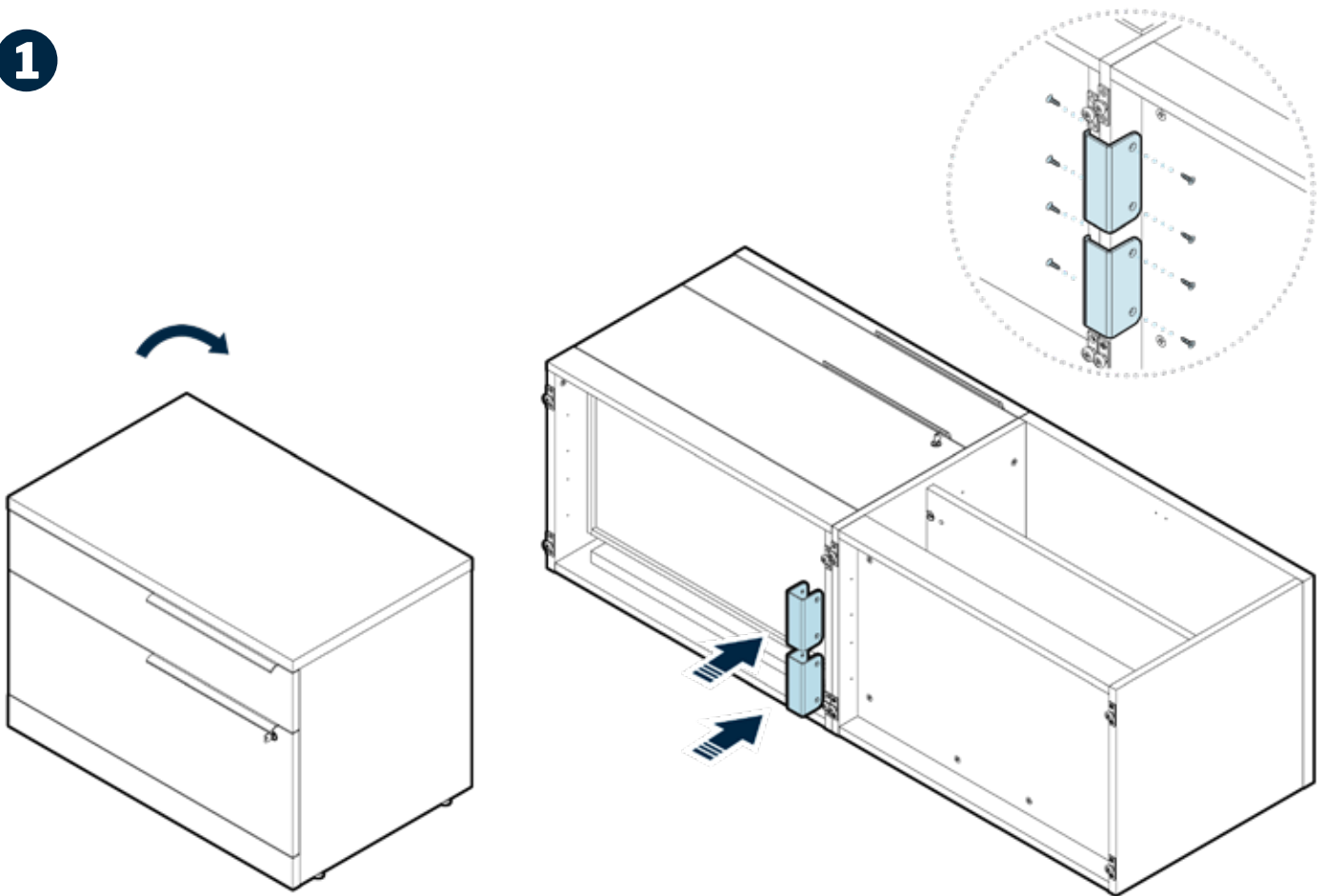

With assistance, tilt the empty lateral file cabinet onto its back, and position it side-by-side with the other piece(s) of furniture. Slide two joining brackets over the adjacent side panel bases, aligning the holes in the brackets with the holes in the panels. Using a Phillips head screwdriver, secure each bracket with four wood screws.

2

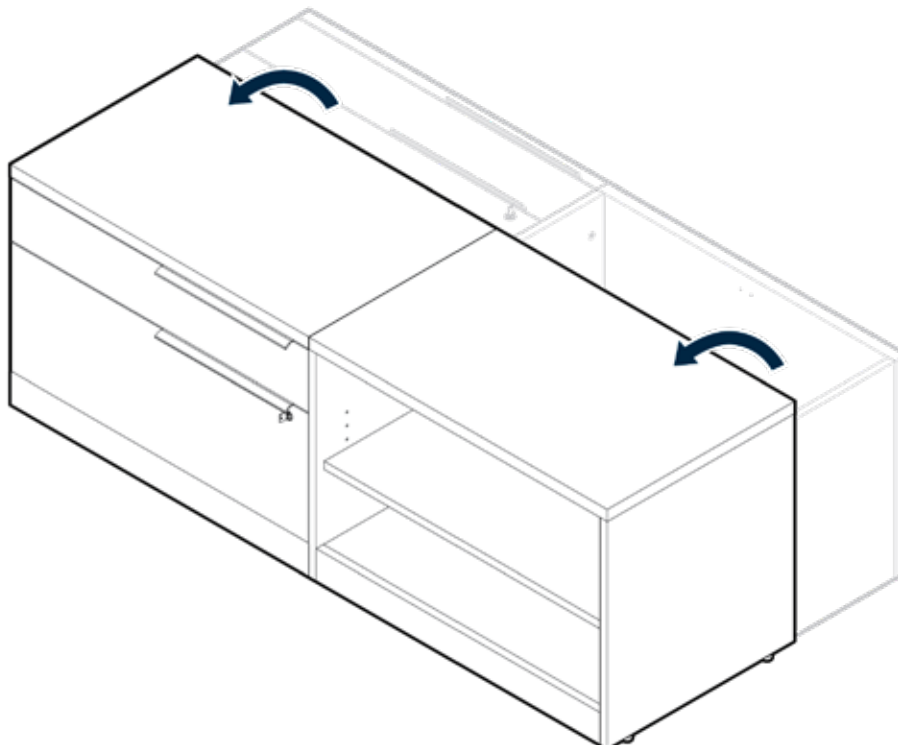

With assistance, tilt the joined pieces onto their feet. Use a ½" wrench to level as needed.

Adjusting the Drawer Pull Placement

1

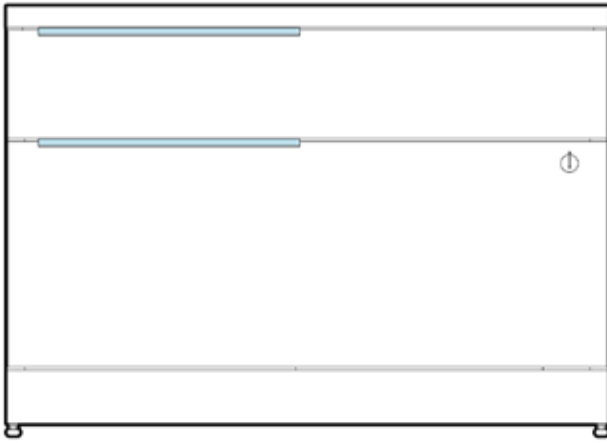

LEFT ALIGN

Left hole on drawer pull aligns to left hole on drawer.

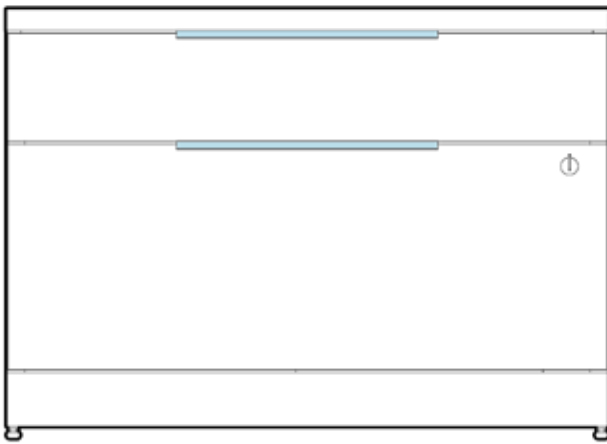
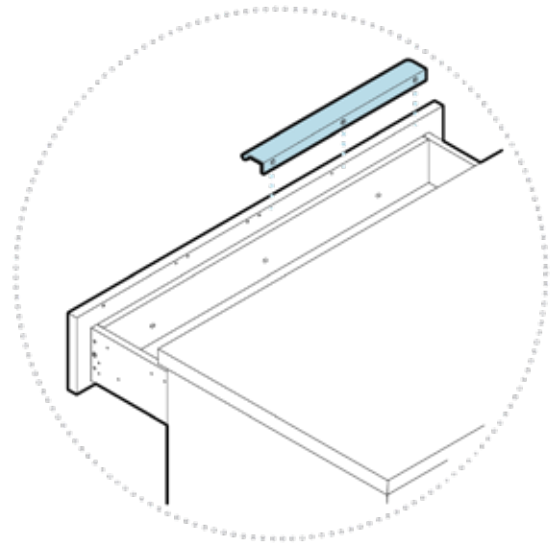

CENTERED

Center hole on drawer pull aligns to center hole on drawer.

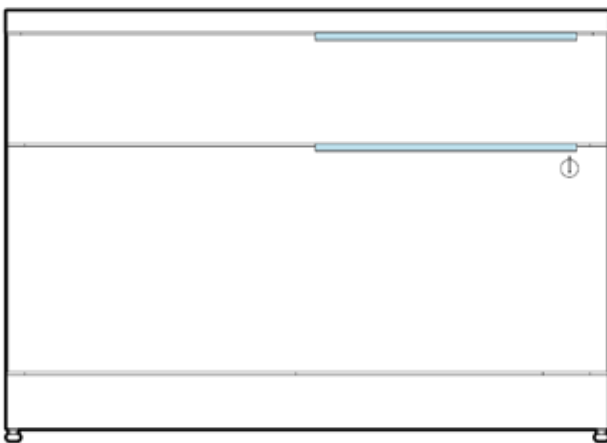
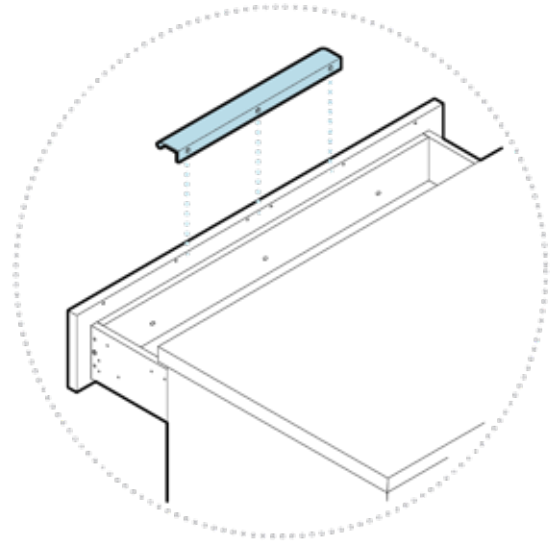

RIGHT ALIGN

Right hole on drawer pull aligns to right hole on drawer.

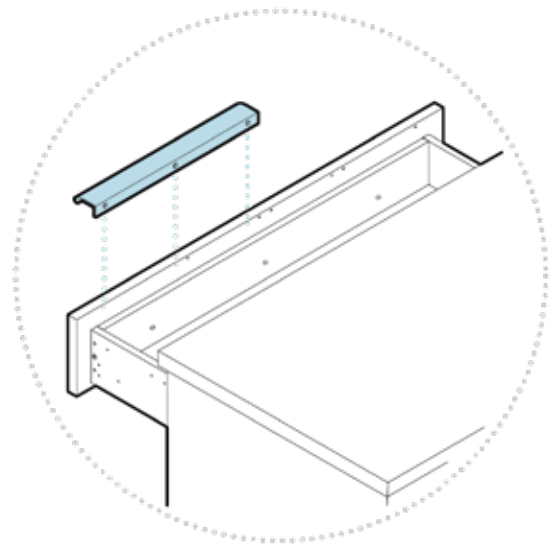

To install the drawer handles, align either the left, center, or right hole on the drawer pull to the predrilled left, center, or right hole on the file cabinet drawer. Secure the drawer pull with 3 wood screws and a Phillips head screwdriver. Repeat for the second drawer.

Installing, Adjusting, and Removing File Hangers

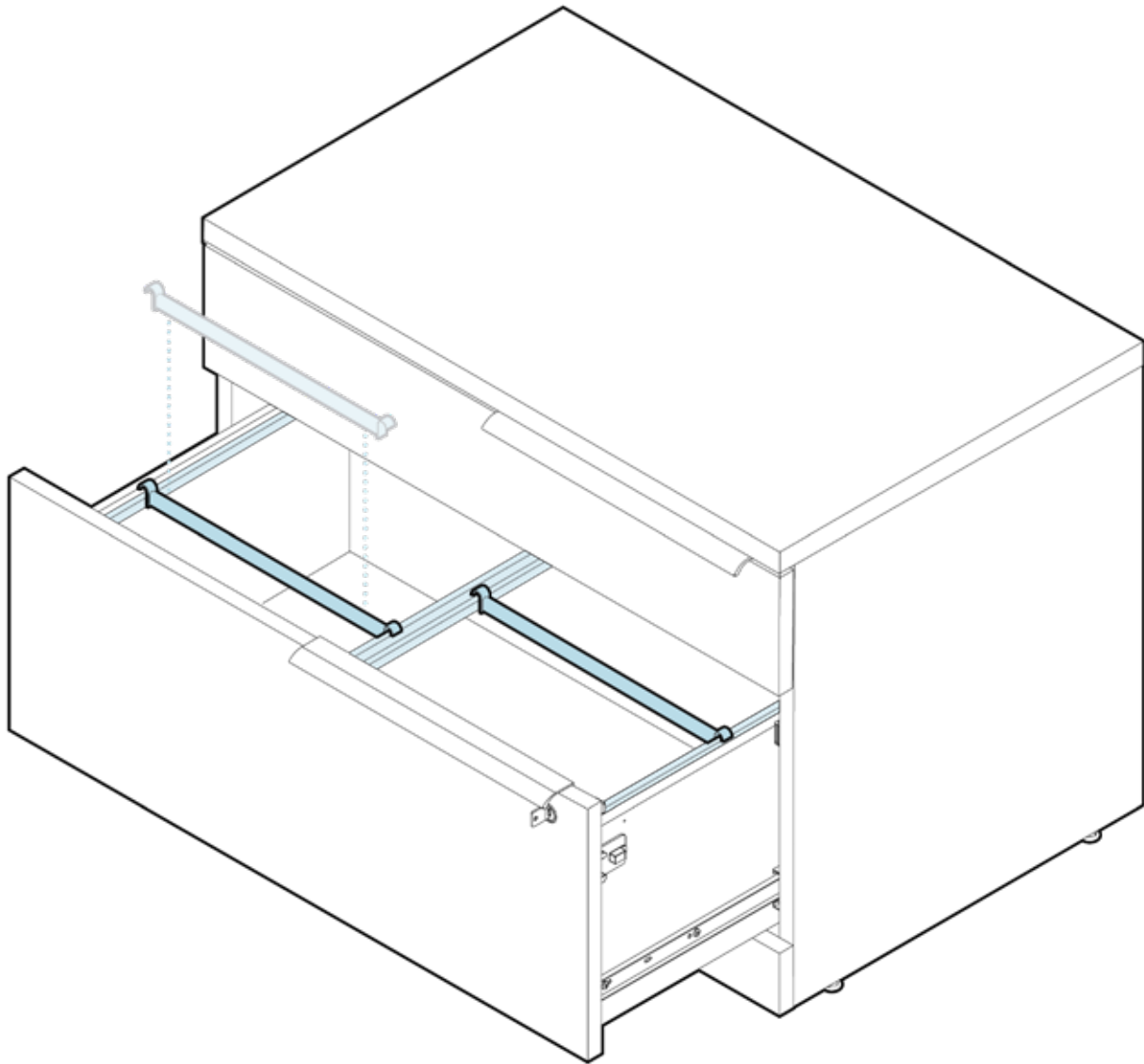

The lateral file cabinet will come with 5 file rails—4 long and 1 short. These can be lowered into place, resting front-to-back or side-to-side on other supporting track. To reposition or remove the file rails, press along the bottom of the supporting track near the file rail to release the locking tooth, then slide the rail into the desired position or lift the rail off the tracks to remove.

The rails can be reconfigured in a number of ways to hang letter, legal, or letter and legal files. Some examples can be found below and on the following page; side-by-side examples are mirrored configurations.

LETTER & LETTER

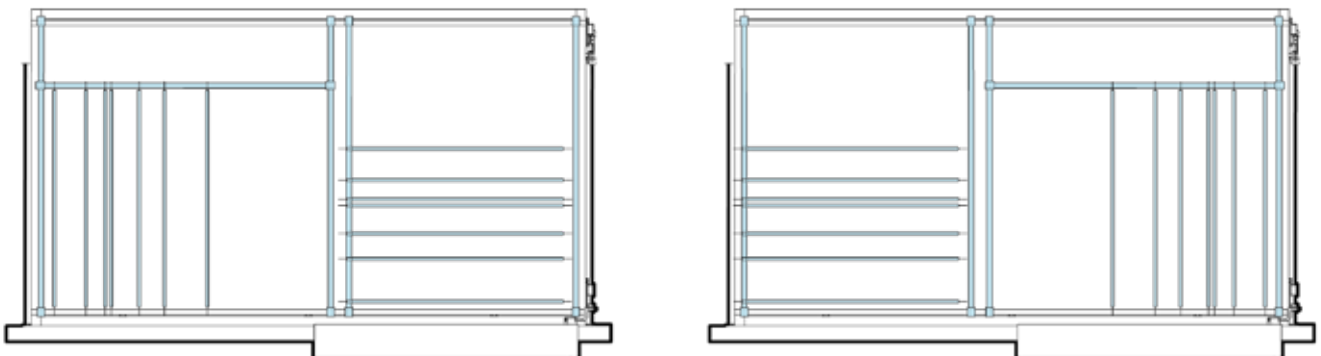

LETTER & LEGAL

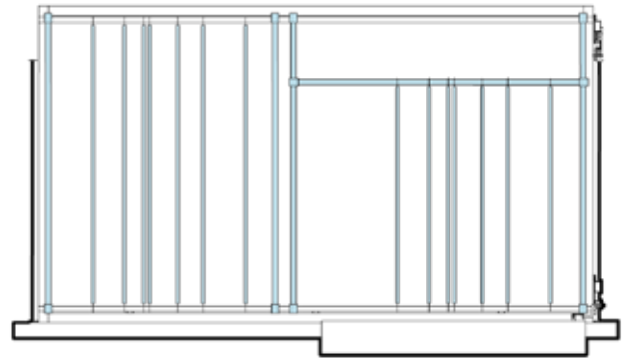
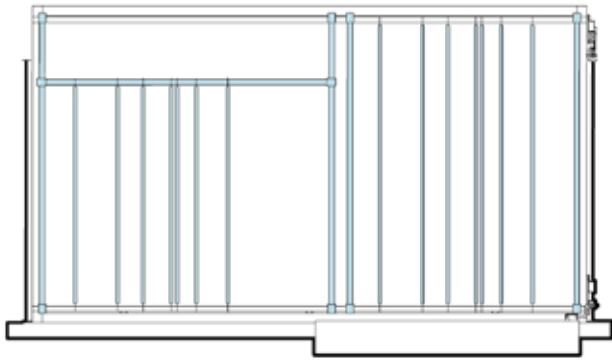

LETTER & LETTER

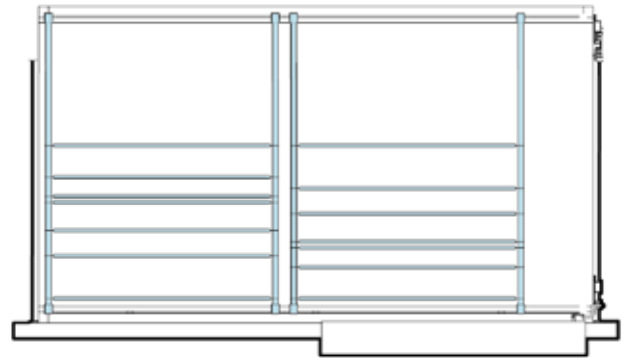
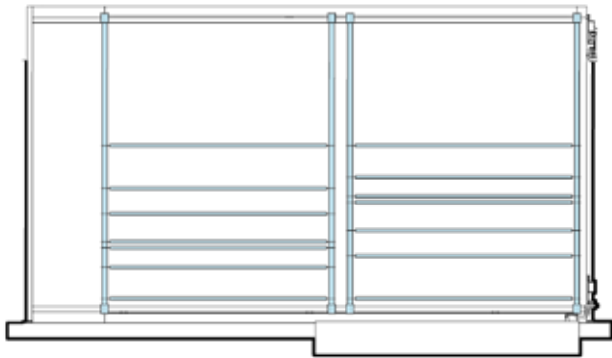

LEGAL & LETTER

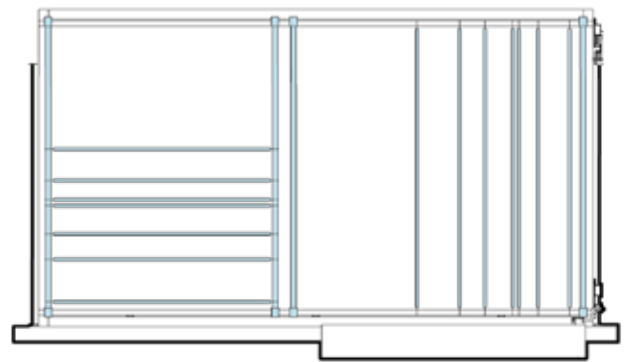
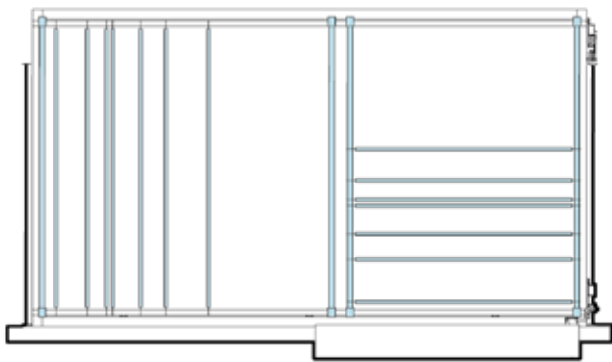

LEGAL & LETTER

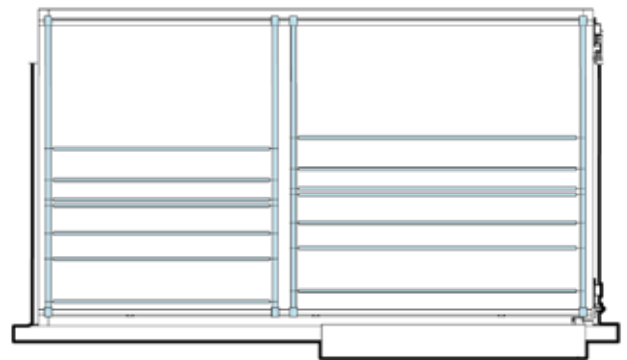
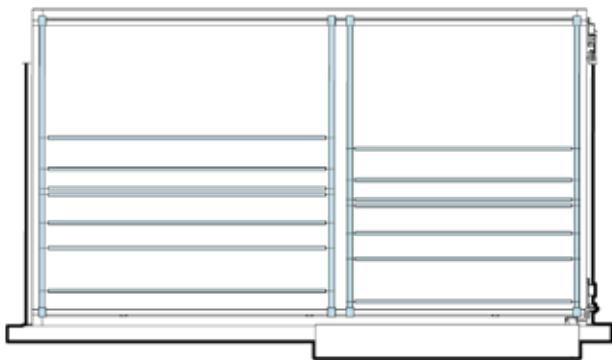

LEGAL & LEGAL

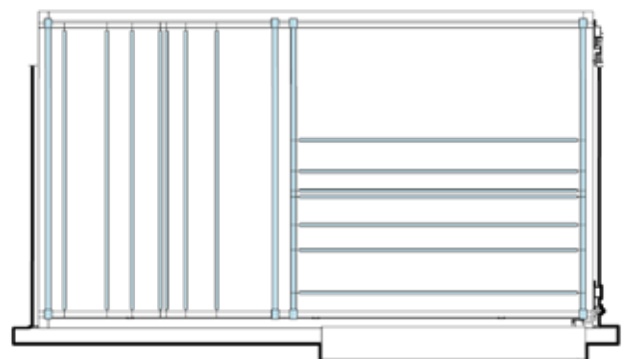
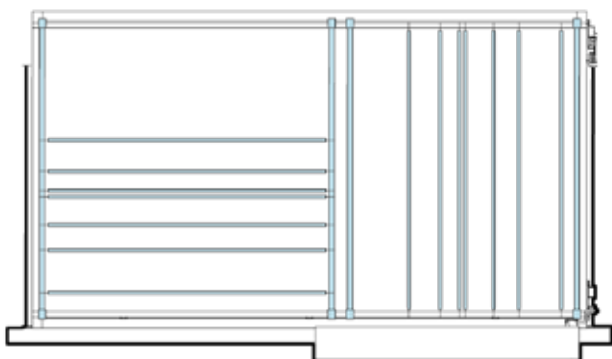

Executive Wardrobe Cabinet

Included Parts

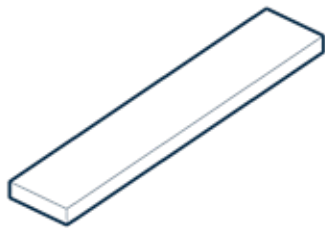

4" VHB TAPE
x4

Tools Needed (Not Included)



PHILLIPS HEAD SCREWDRIVER
x1

Switching the Door Orientation

1

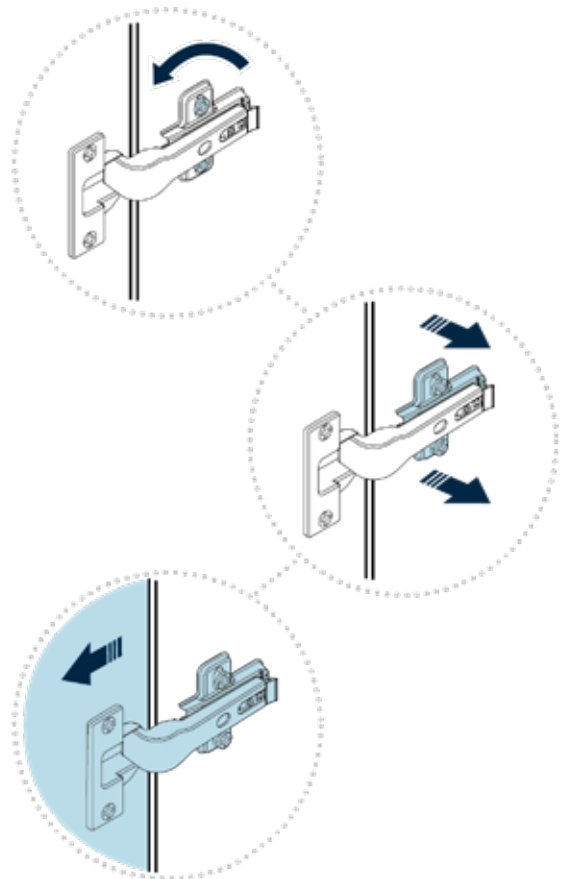
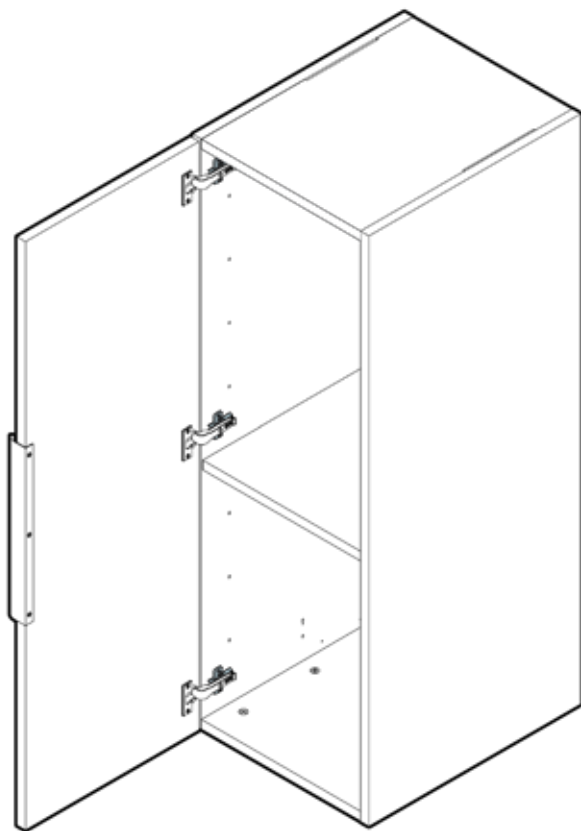

To change the side the door opens toward, open the cabinet. Turn a Phillips head screwdriver counterclockwise to unscrew the hinges, separating them from the inside of the cabinet.

2

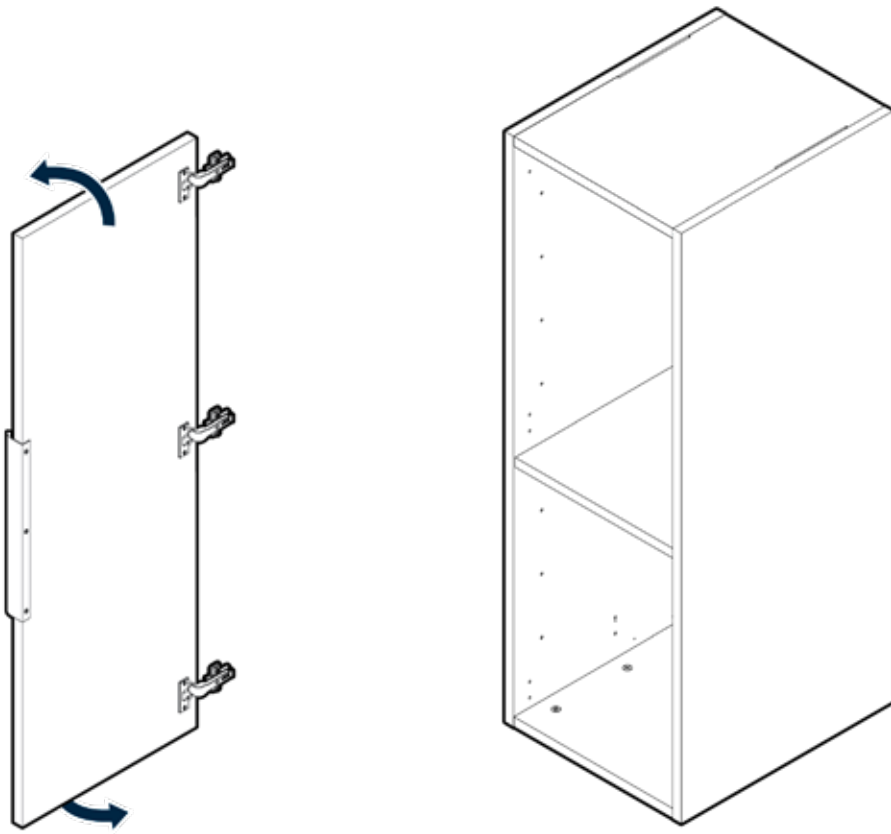

Remove the door, and flip it upside down.

3

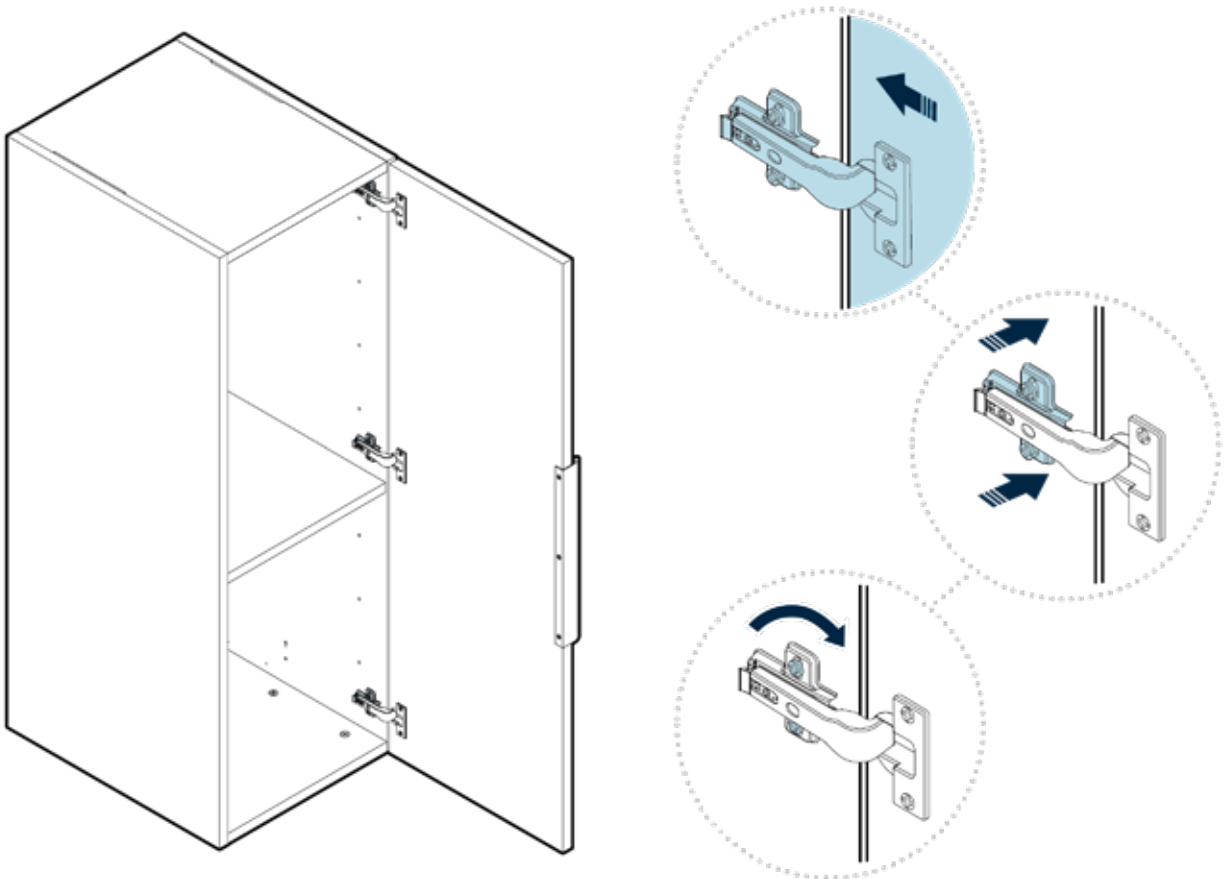

Locate the predrilled holes on the other side of the cabinet. Align the holes on the hinges with the holes on the inside of the cabinet. Turning a Phillips head screwdriver clockwise, fasten the hinges with the screws previously removed.

Adjusting the Shelf Placement

1

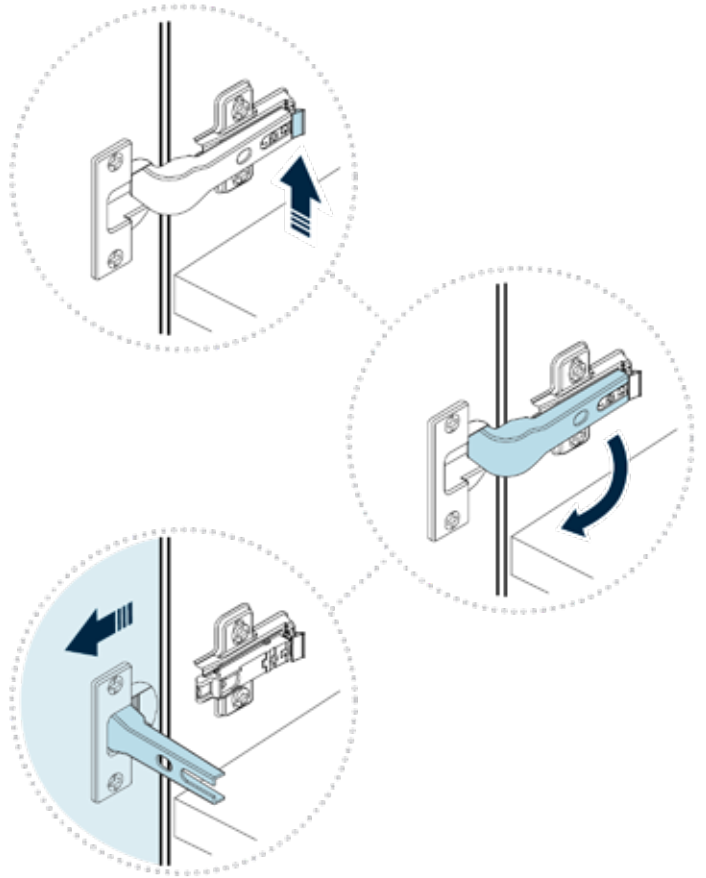
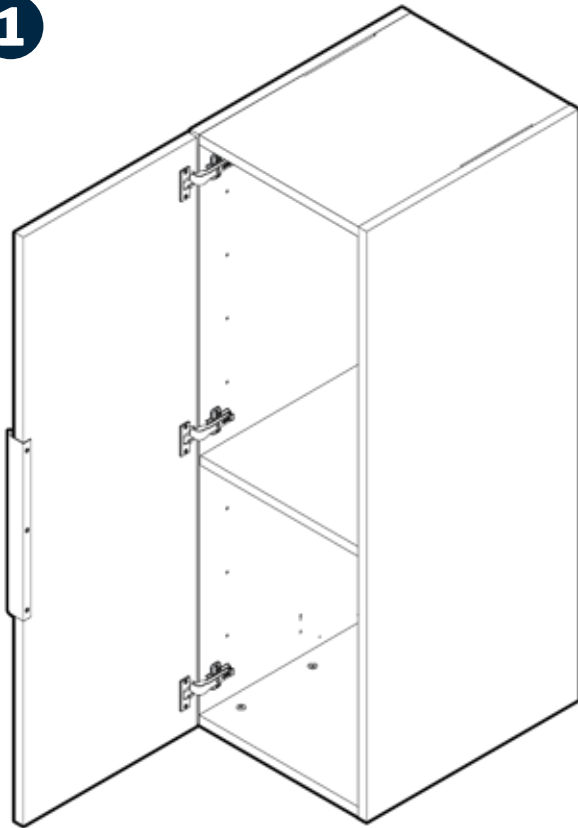

Open the wardrobe cabinet. With one person holding the open door, another should remove the door by pressing the indicated lever to release the door glide, swinging the door glide out, and moving the door away from the cabinet.

NOTE: Be careful not to pinch fingers!

2

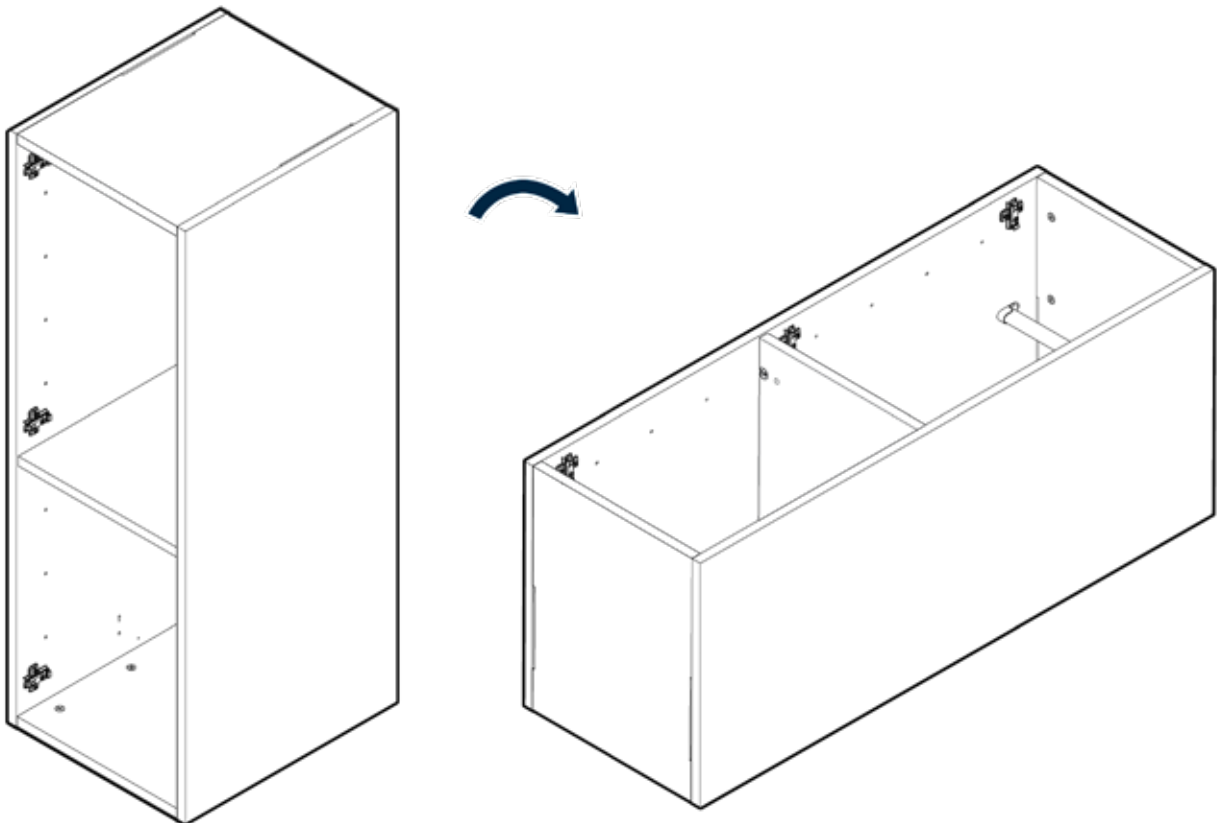

With assistance, tilt the empty wardrobe cabinet onto its back.

3

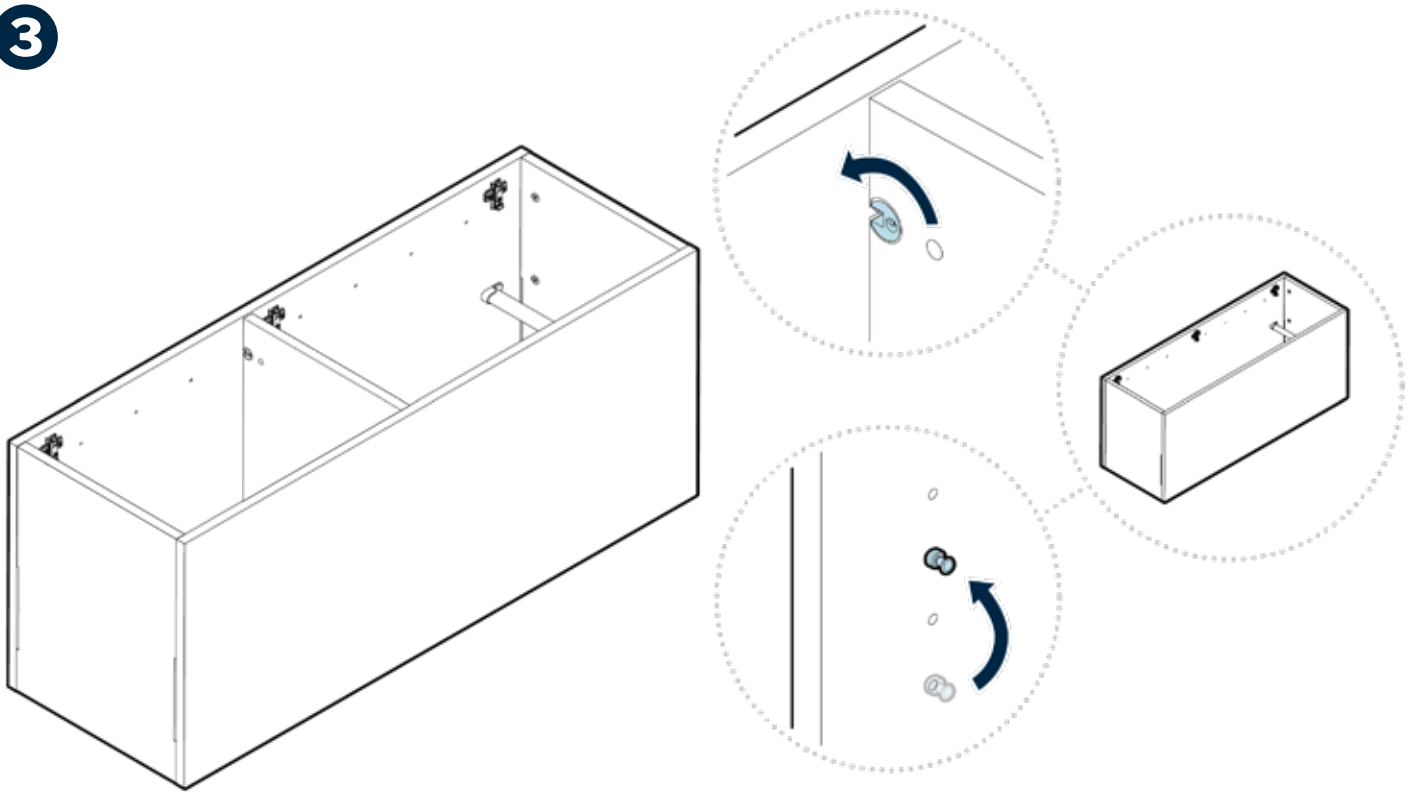

On the bottom of the shelf, there are 4 mini fix cams holding the shelf in place. To unlock the shelf, use a Phillips head screwdriver to turn the mini fix cams to the left. Remove the shelf, then move each peg to the desired position; all four pegs should be in the same position.

Place the shelf back in place, aligning the mini fix cams with the repositioned pegs. To secure the shelf to the pegs, use a Phillips head screwdriver to turn the mini fix cams to the right until tight. With assistance, tilt the wardrobe cabinet back upright.

4

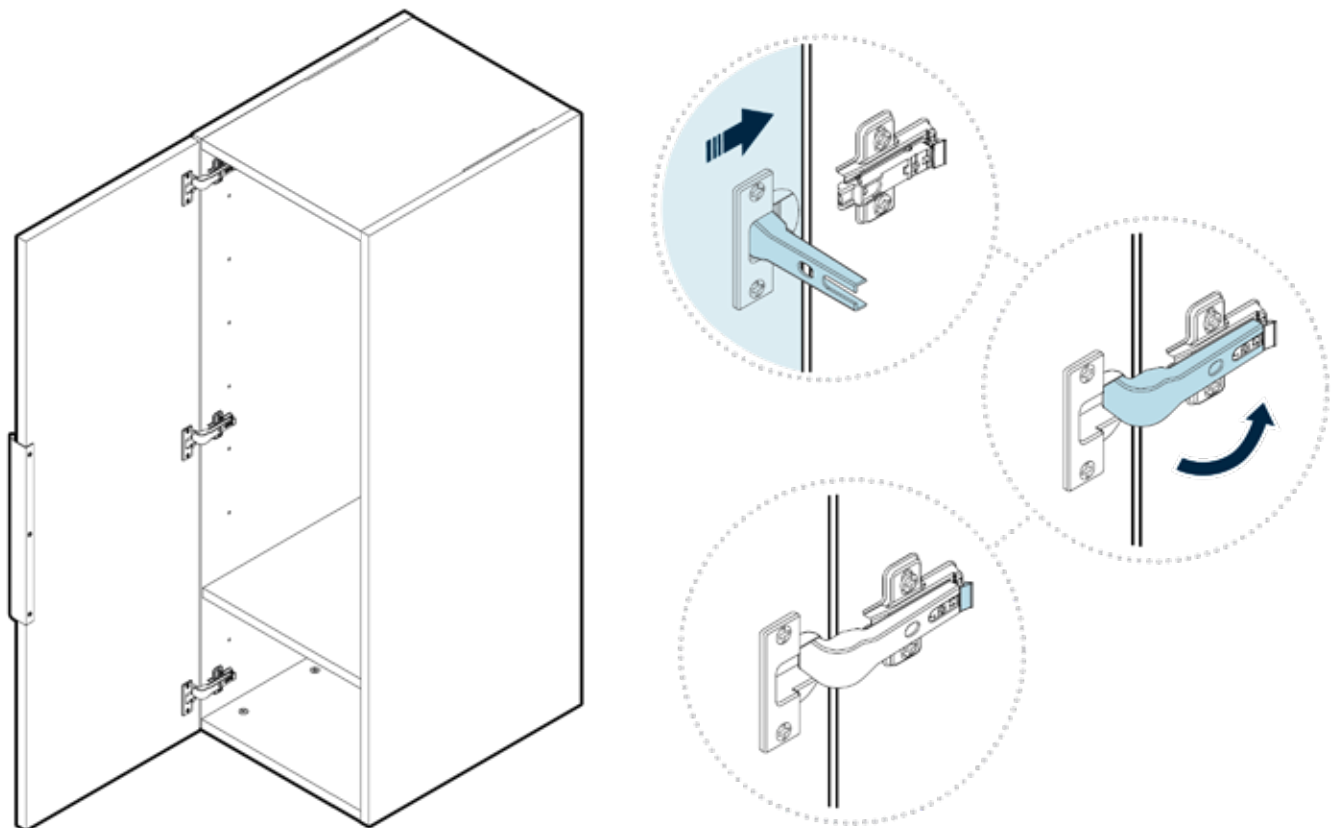

NOTE: Be careful not to pinch fingers! With one person holding a door in place, another person should reattach the door by swinging the door guide in, pressing the glide in place, and confirming the lever and guide are secure.

Joining the Executive Wardrobe Cabinet with Lower Credenza Pieces

1

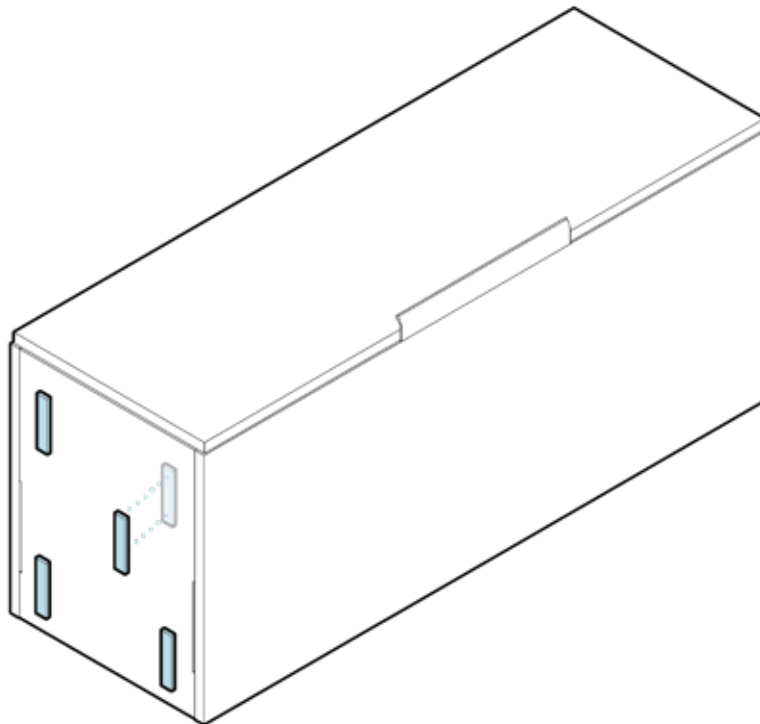

With assistance, tilt the wardrobe cabinet onto its back. Remove the backing from one side of the provided 4" pieces of VHB tape, and apply it to one of the 4 corners of the bottom panel. Repeat with the remaining 3 pieces. With all 4 pieces applied to the wardrobe cabinet, remove the backing from the exposed side.

NOTE: The VHB tape's adhesive is very strong, and the tape should not be removed once applied. Attempts to remove it may result in damage to the product.

2



With assistance, tilt the cabinet onto its back edge, then lift it up. Carefully hover the cabinet over the lower cabinets. **(NOTE: If installing on a credenza of joined cabinets, the credenza should be 96" wide and already in its final arrangement.)** After ensuring all back and side panels are flush with each other, lower the cabinet into place.

Executive Overhead Cabinet

Parts Needed If Joining with Other Pieces (Not Included)

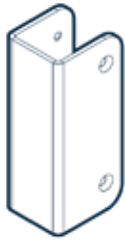

JOINING BRACKET
x2



3/4" PHILLIPS DRIVE
WOOD SCREWS
x8

Tools Needed (Not Included)



PHILLIPS HEAD SCREWDRIVER
x1

Joining an Executive Overhead Cabinet with Executive Wardrobe Cabinets

1

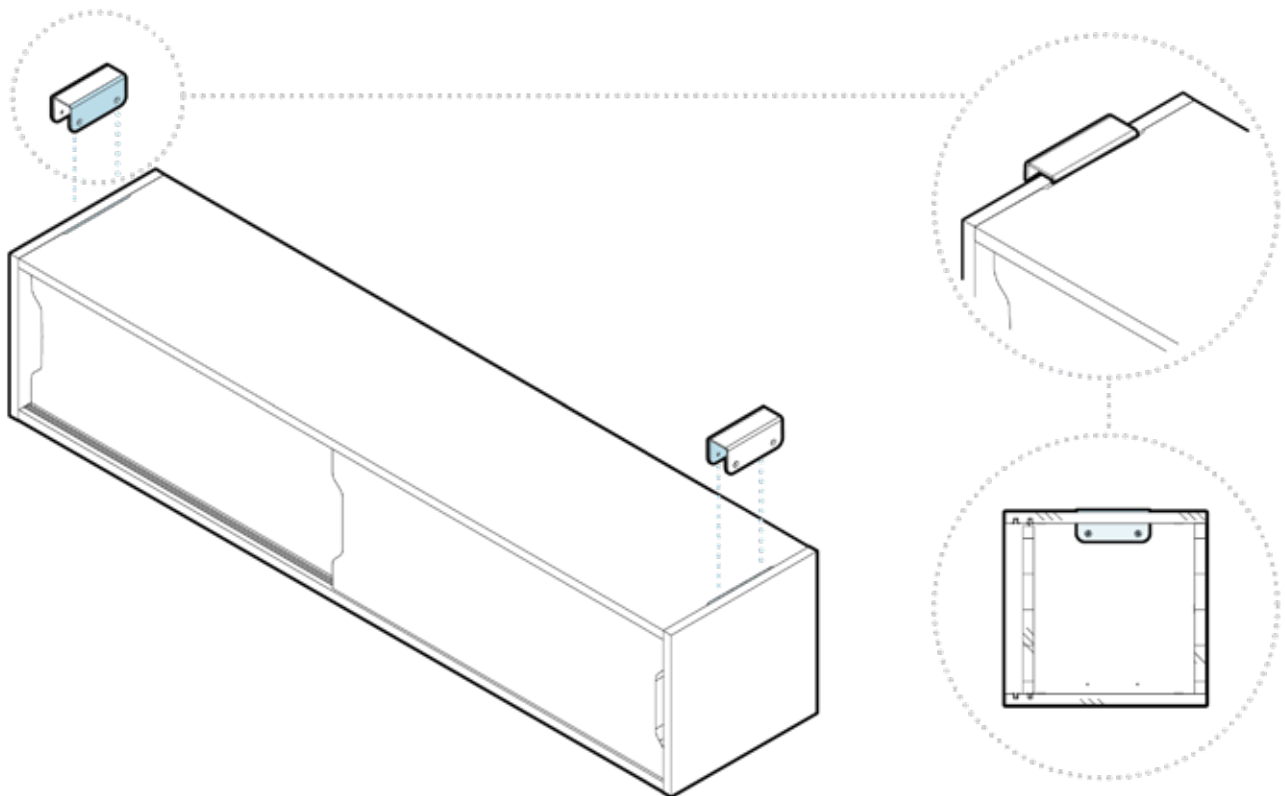

Overhead cabinets can be installed between two wardrobe cabinets to sit on top of a 96" lower credenza. Lower one side of a joining bracket into a slot on top of the overhead cabinet. Using a Phillips head screwdriver and two of the provided wood screws, attach the bracket to the inside of the overhead cabinet. Repeat for the second end.

2

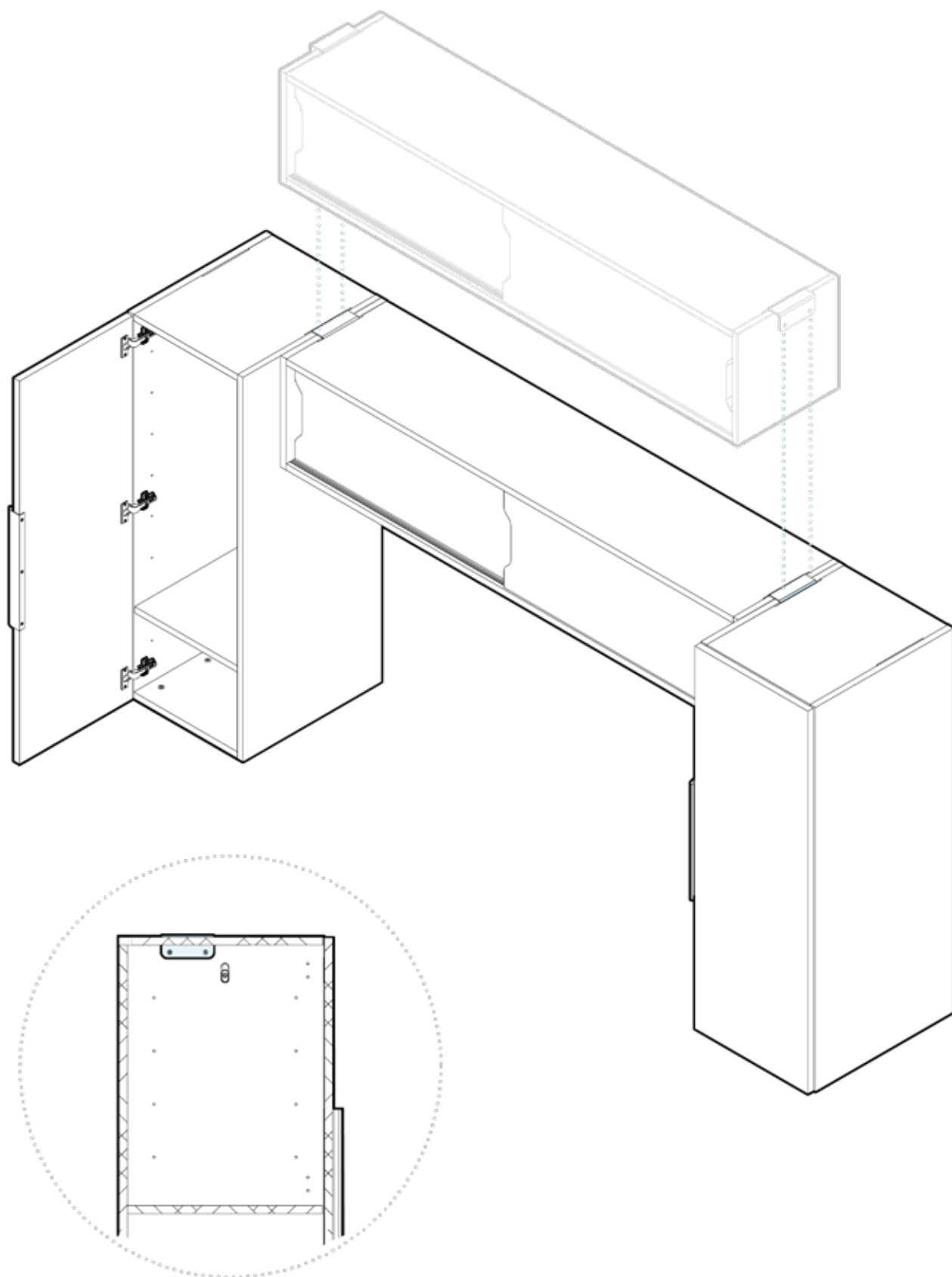

With assistance, carefully lower the overhead cabinet onto two wardrobe cabinets, with the joining brackets sliding into the slots on top of the wardrobe cabinets.

To finish securing the cabinets together, open the wardrobe cabinet doors. Using a Phillips head screwdriver and the remaining wood screws, fasten the brackets to the inside walls.

Executive Desk

Included Parts

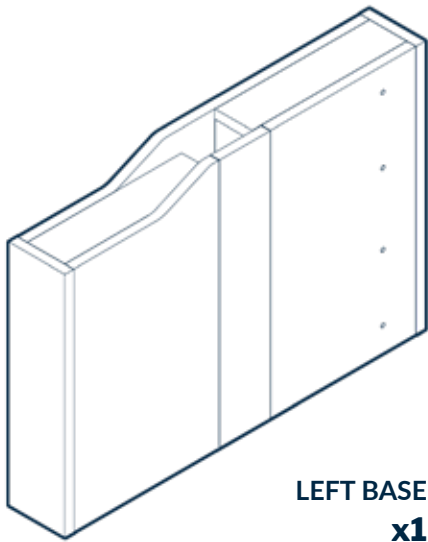

LEFT BASE
x1

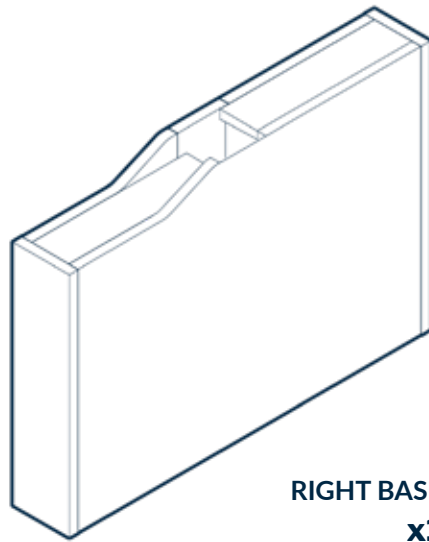

RIGHT BASE
x1



1 1/2" DOWELS
x4



6mm x 45.5mm
MINI FIX STUD
x4

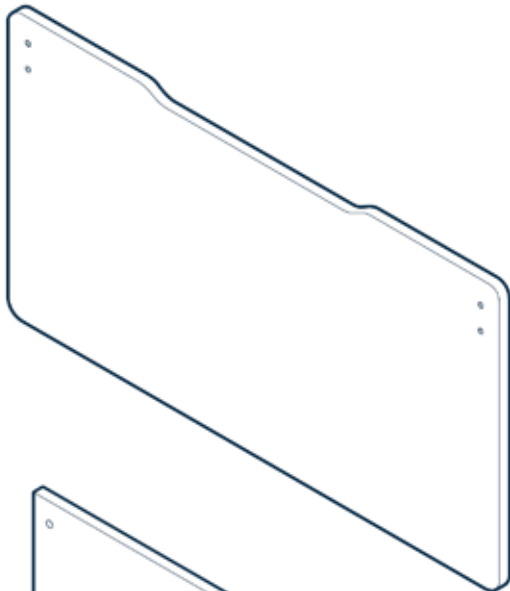

MODESTY
PANEL
x1



15mm x 14mm
MINI FIX CAM
x4



M8 PAN HEAD
PHILLIPS SCREW
x2



3/4" PHILLIPS DRIVE
WOOD SCREWS
x4

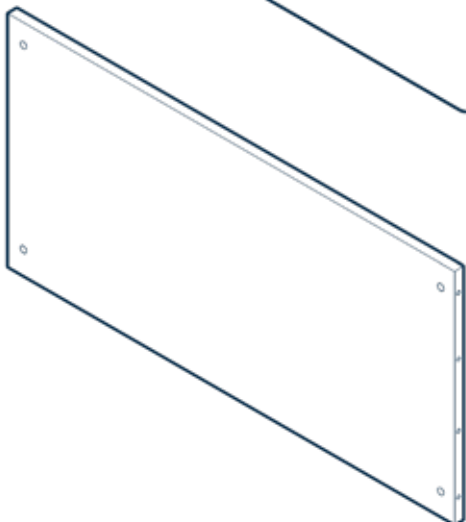

LOWER MODESTY
PANEL
x1



MODESTY PANEL
BRACKET
x2



ADHESIVE
ROUNDS
x4

Tools Needed (Not Included)



PHILLIPS HEAD SCREWDRIVER
x1

Installing the Executive Desk Base and Lower Modesty Panel

1

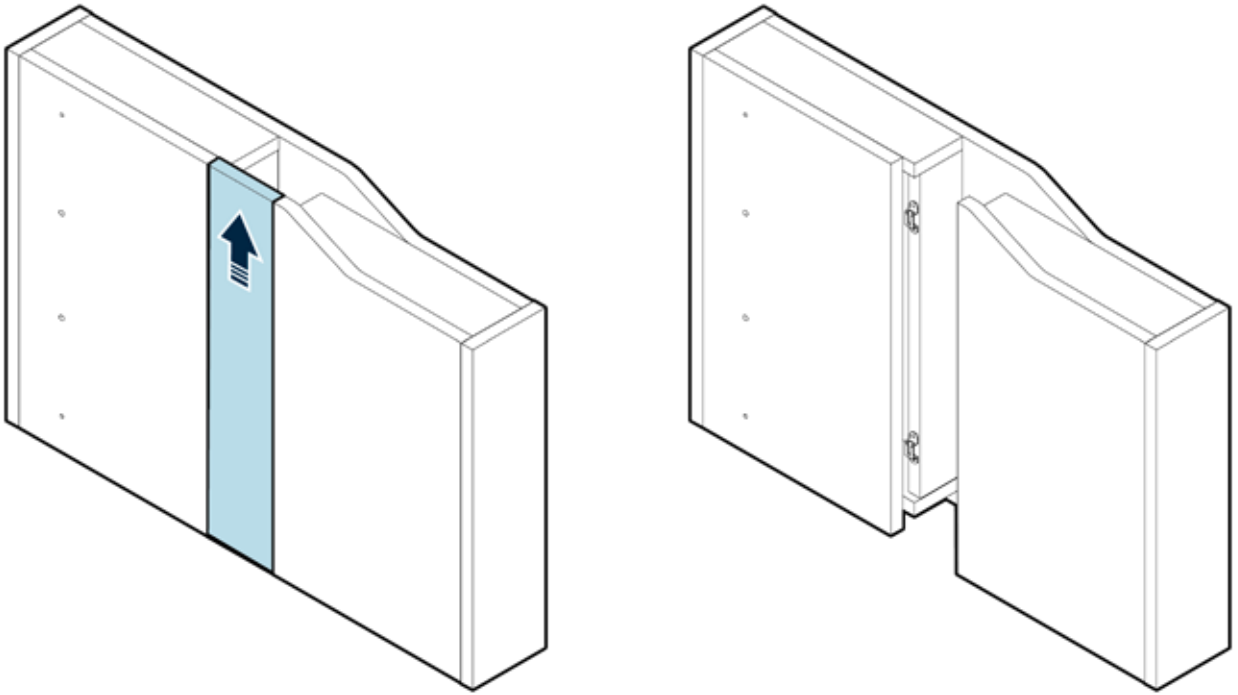

To remove the panel on the inside of the right base, slide it up to release it from the latches.

2

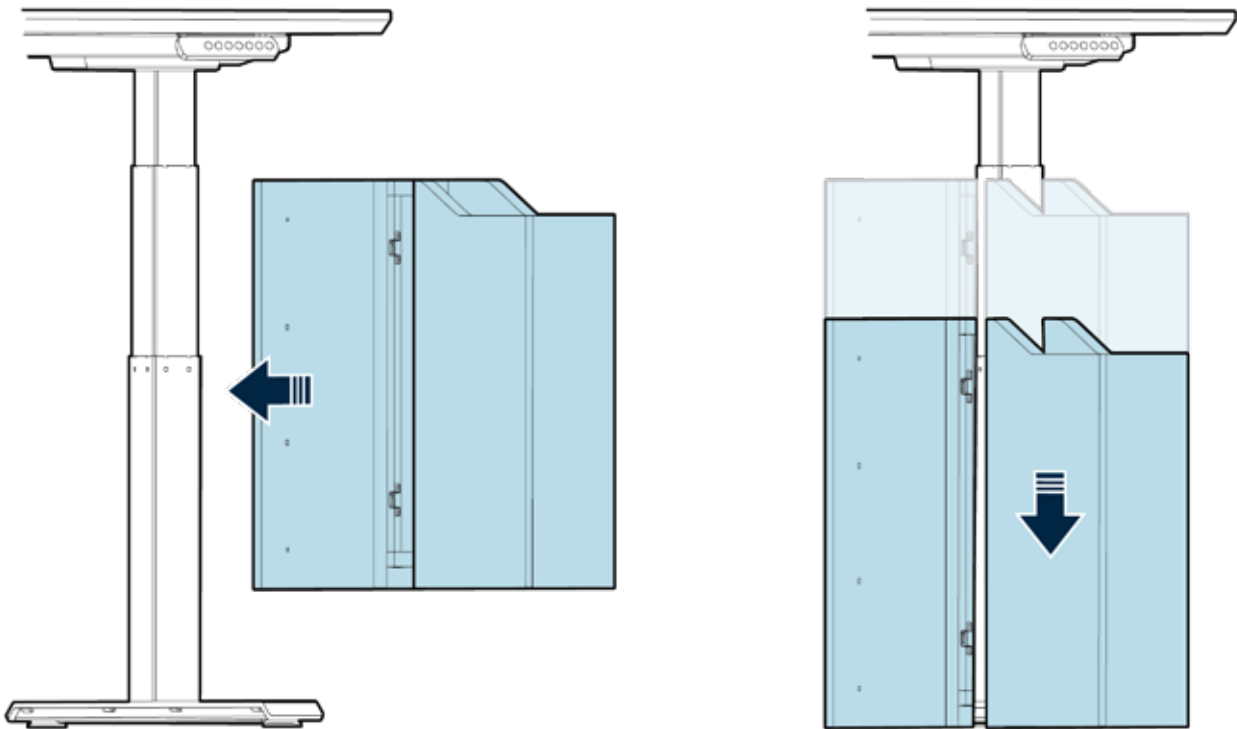

Slide the open right base around the right leg, then lower it into place over the right foot.

3

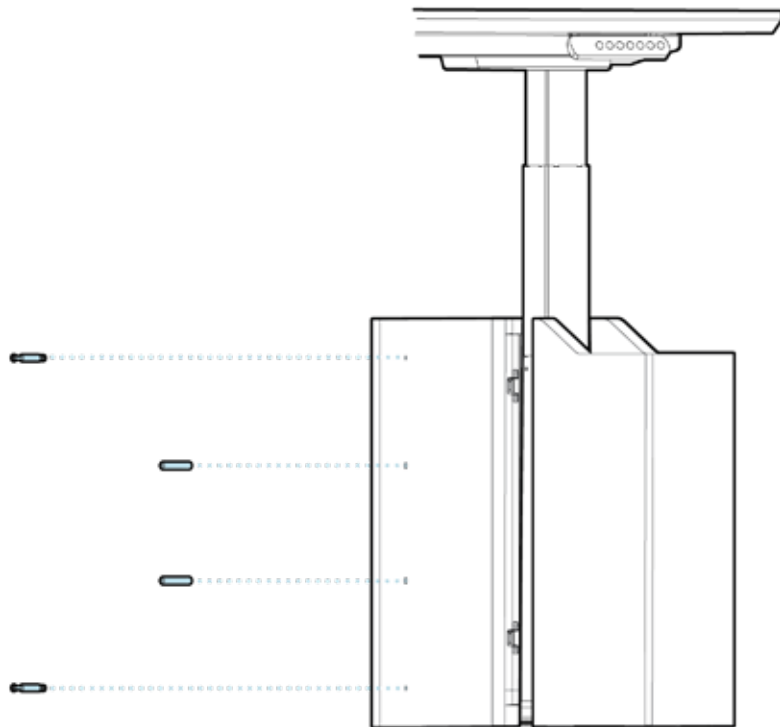

Insert two of the dowels into the middle two holes on the right base. Then, using a Phillips head screwdriver, screw in two of the mini fix studs into the top and bottom holes.

4

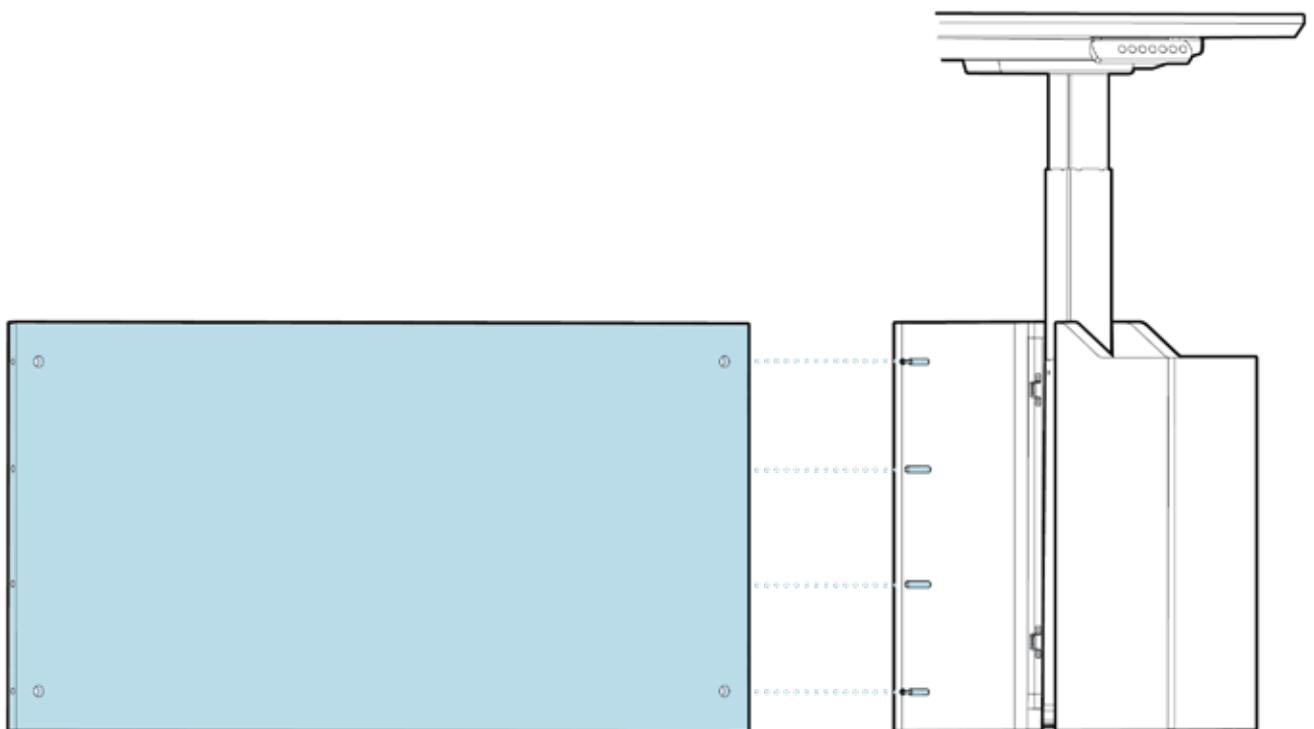

Slide the right end of the lower modesty panel onto the dowels and mini fix studs.

5

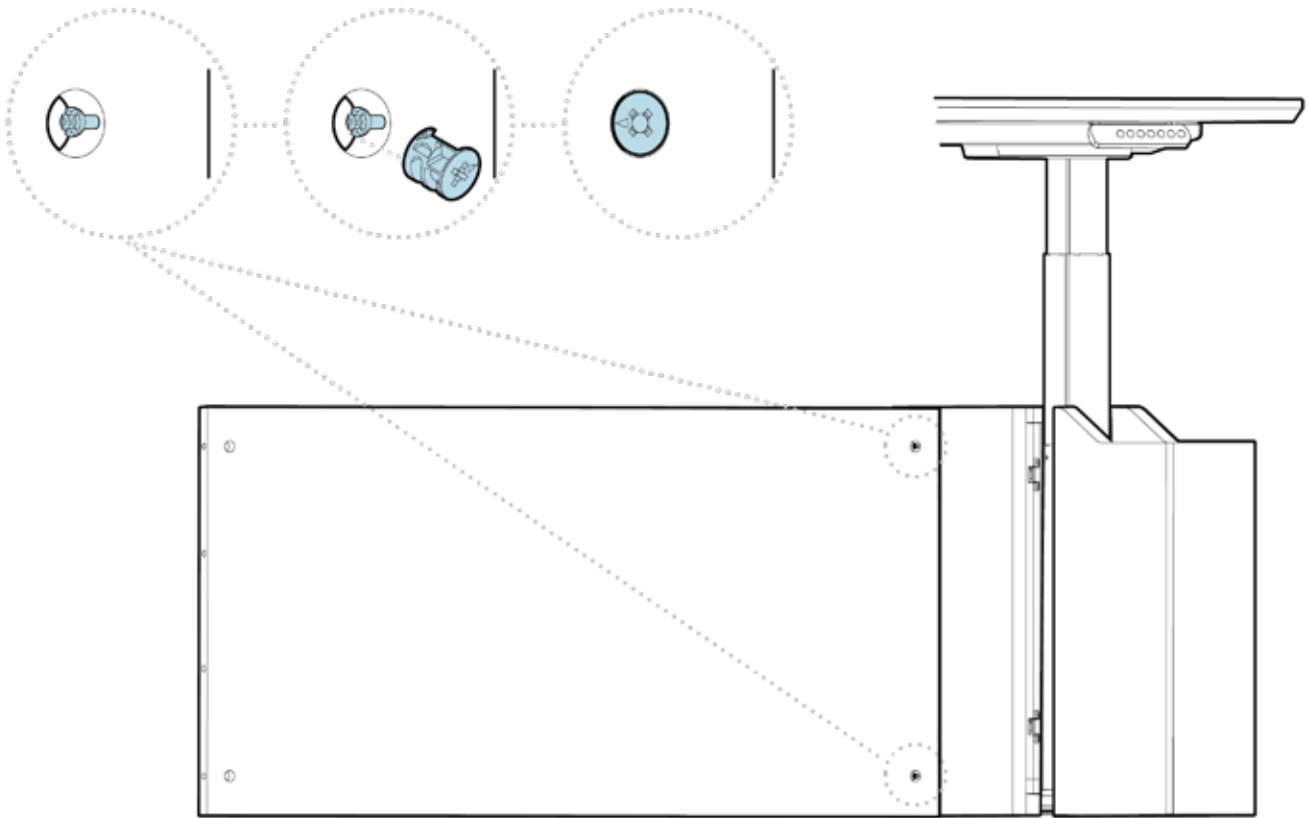

The mini fix studs should be visible in the holes. Insert the mini fix cams into the holes, with the arrows facing the right base. Once the mini fix cams are flush with the panel, use a Phillips head screwdriver to turn them until the arrows face away from the right base.

6

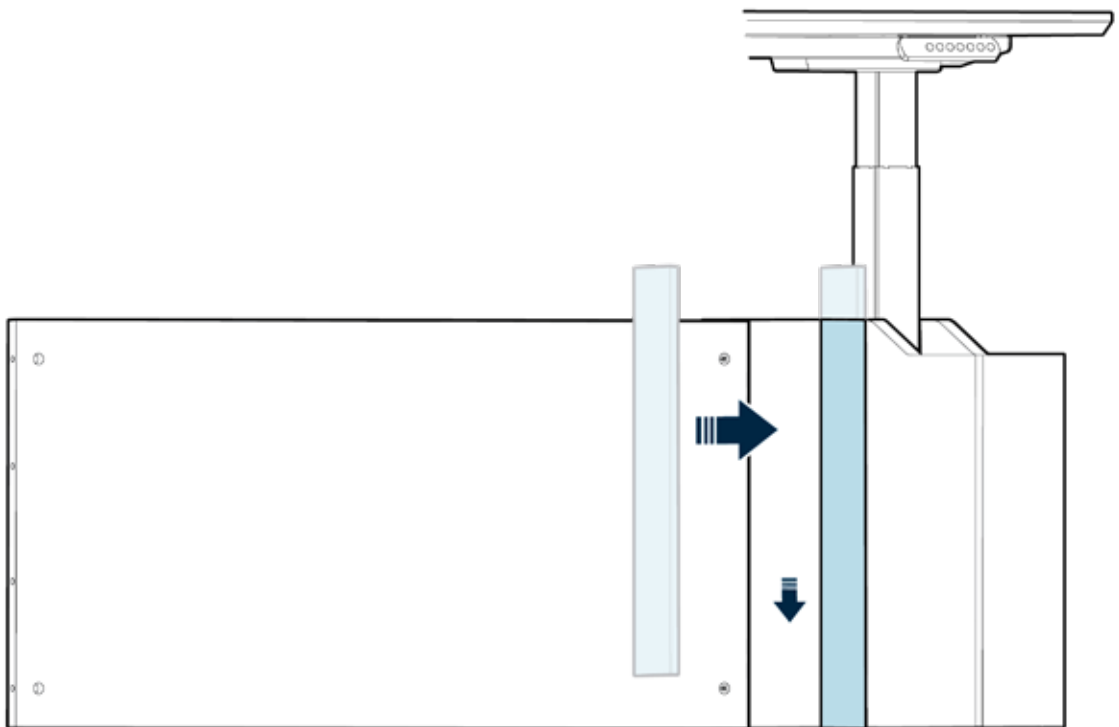

Reinstall the panel on the inside of the right base by aligning it with the base opening and lowering it into place until the pegs catch on the latches.

7

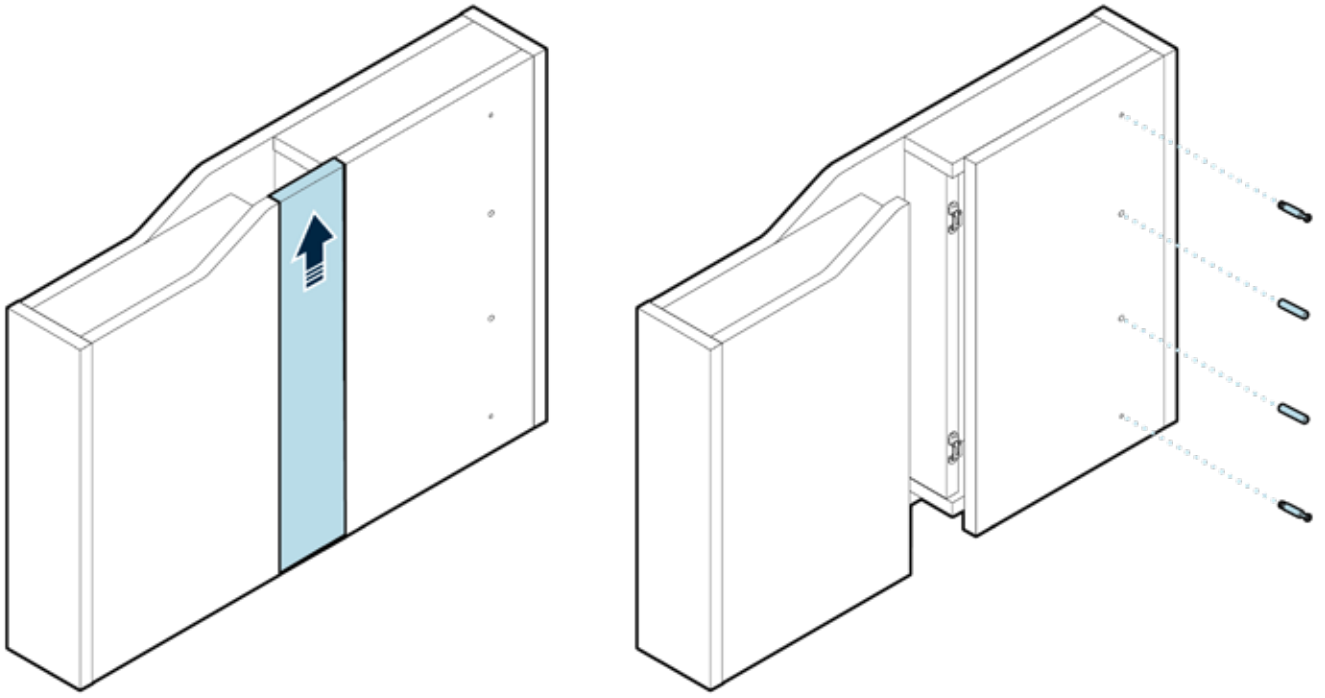

Remove the panel on the inside of the left base, sliding it up to release it from the latches. Insert two of the dowels into the middle two holes on the left base. Then, using a Phillips head screwdriver, screw in two of the mini fix studs into the top and bottom holes.

8

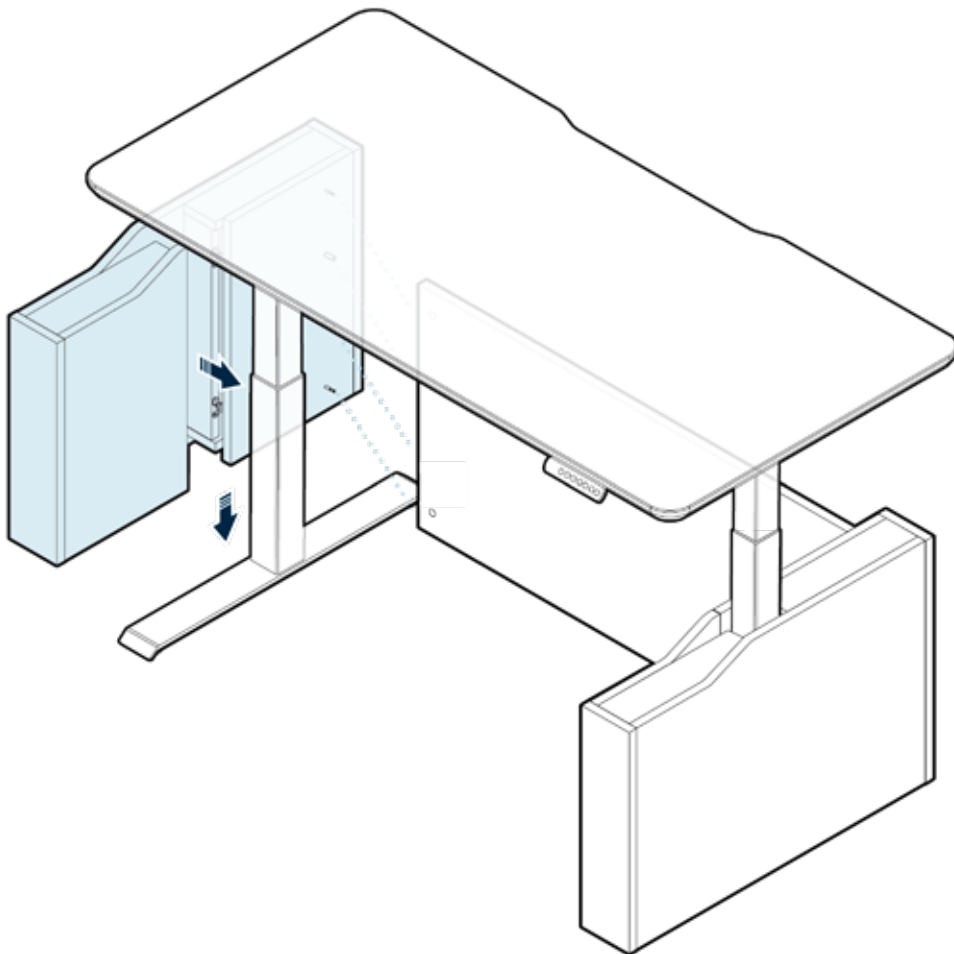

Slide the left base around the left leg of the desk, then lower it into place over the left foot of the desk. Make sure to line up the dowels and mini fix studs with the holes on the lower panel.

9

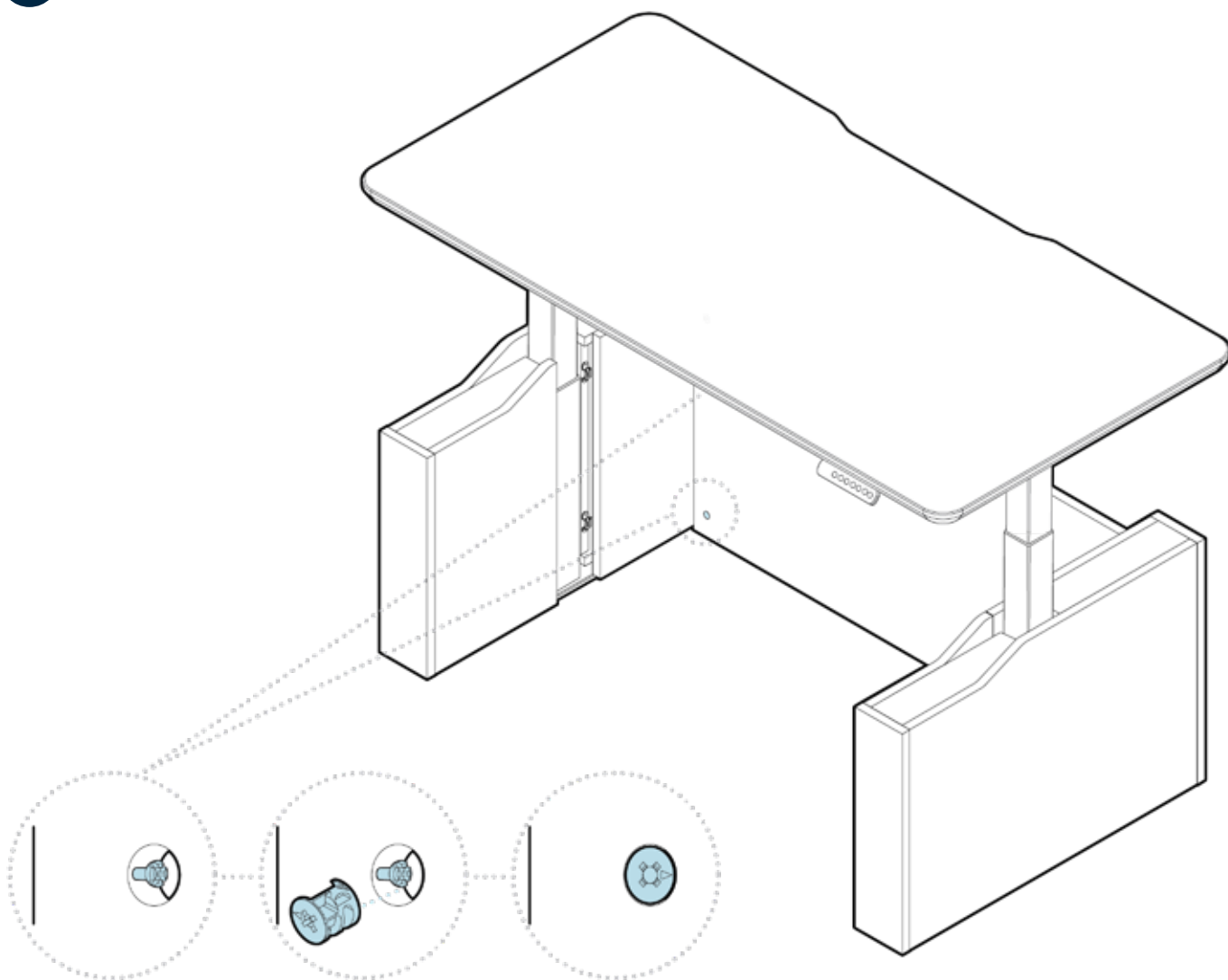

The mini fix studs should be visible in the holes. Insert the mini fix cams into the holes, with the arrows facing the left base. Once the mini fix cams are flush with the panel, use a Phillips head screwdriver to turn them until the arrows face away from the left base.

The set of 4 adhesive rounds can be placed over the mini fix cams to hide them.

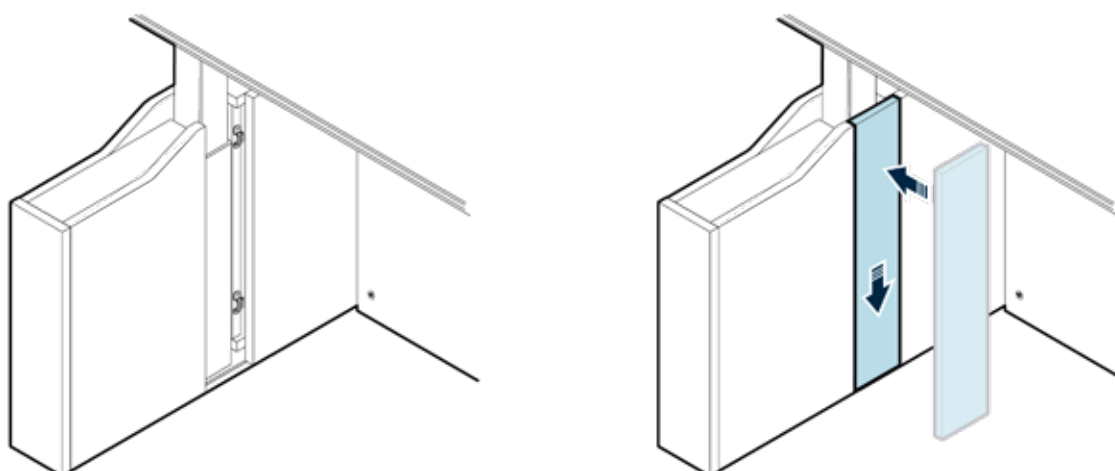

Reinstall the panel on the inside of the left base by aligning it with the base opening and lowering it into place until the pegs catch on the latches.

Installing the Modesty Panel

1

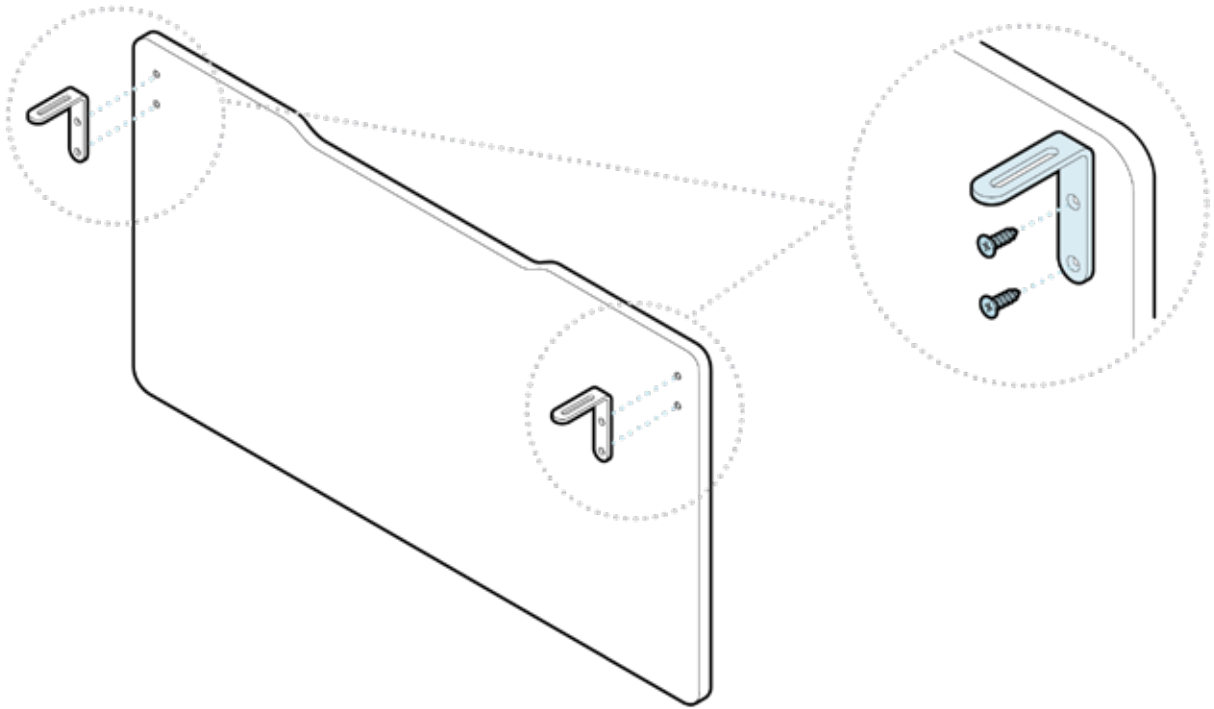

Attach the brackets to the modesty panel using provided four wood screws and a Phillips head screwdriver.

2

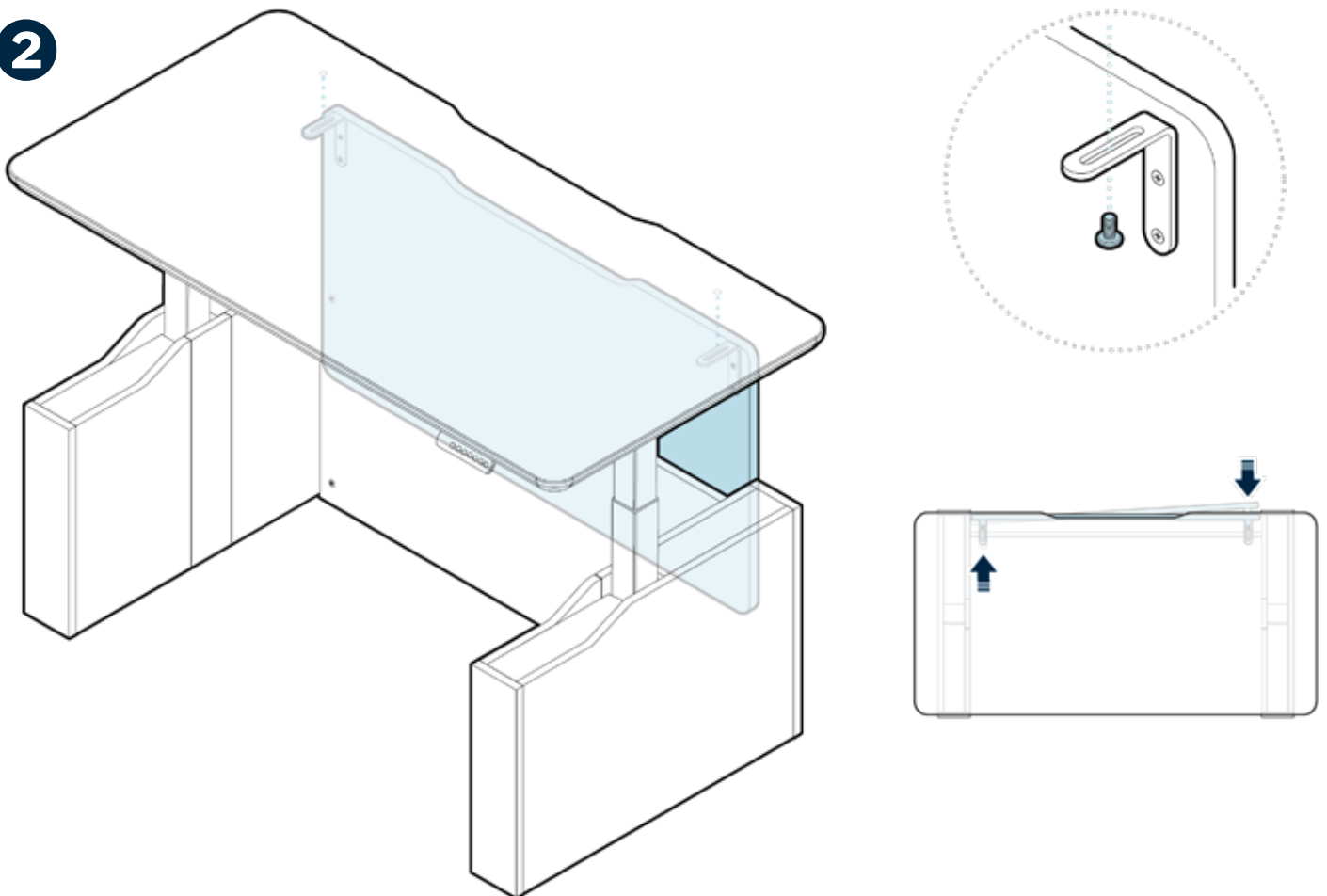

With assistance, lift the panel to the bottom side of the desk, aligning the panel's brackets with the insert nuts on the bottom of the desk. Thread the pan head screws through the bracket openings, and secure them to the desk using a Phillips head screwdriver. Be sure the panel is straight and not hitting the lower panel; if adjustments are needed, loosen the screws, slide the bracket into the desired position, and retighten. Confirm the panel is secure before use.



(800) 207-2587