

Standing Round Table / Standing Square Table



2 People
Required



Holds up to
300 lb (136 kg)

vari[®]

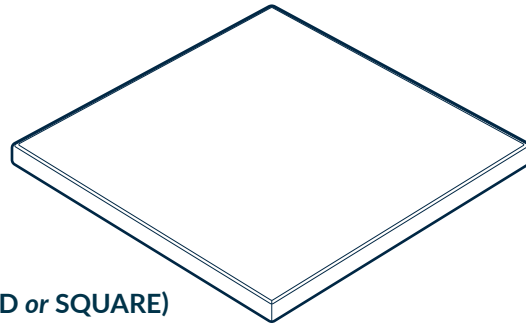
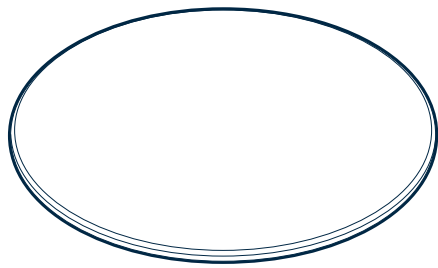
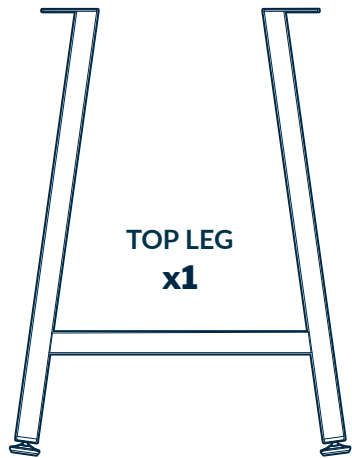
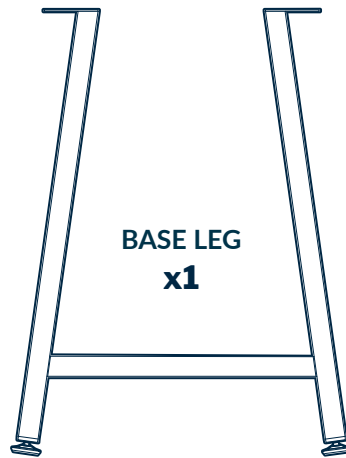

TABLE TOP (ROUND or SQUARE)

x1



TOP LEG
x1



BASE LEG
x1



WASHER
x2

SPACER
x1

NUT
x1

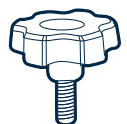

HAND SCREW
x4



BOLT
x1

REQUIRED TOOLS (Included)



17MM WRENCH
x1



5MM ALLEN KEY
x1

1

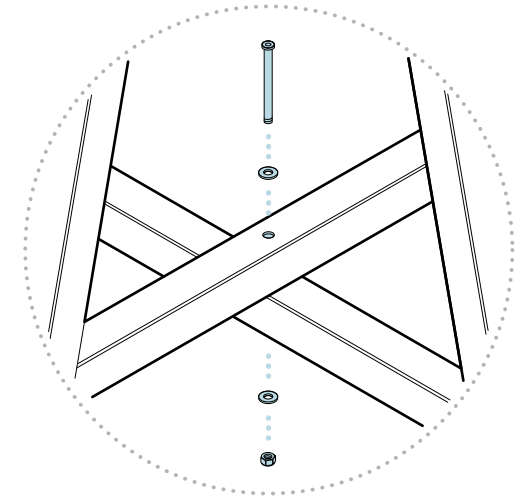
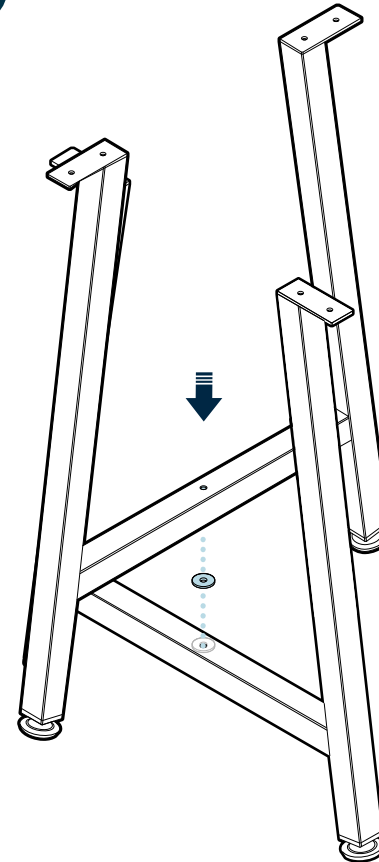

Place the spacer on top of the base leg crossbar, and make sure it drops into place. Then, place the top leg on the spacer, lining up the holes. Line up the bolt, washers, and nut in order to sandwich the legs and hold everything in place. Using the wrench to hold the nut still, turn the bolt with the Allen Key until tightly fastened.

NOTE: The base leg has a lower crossbar than the top leg.

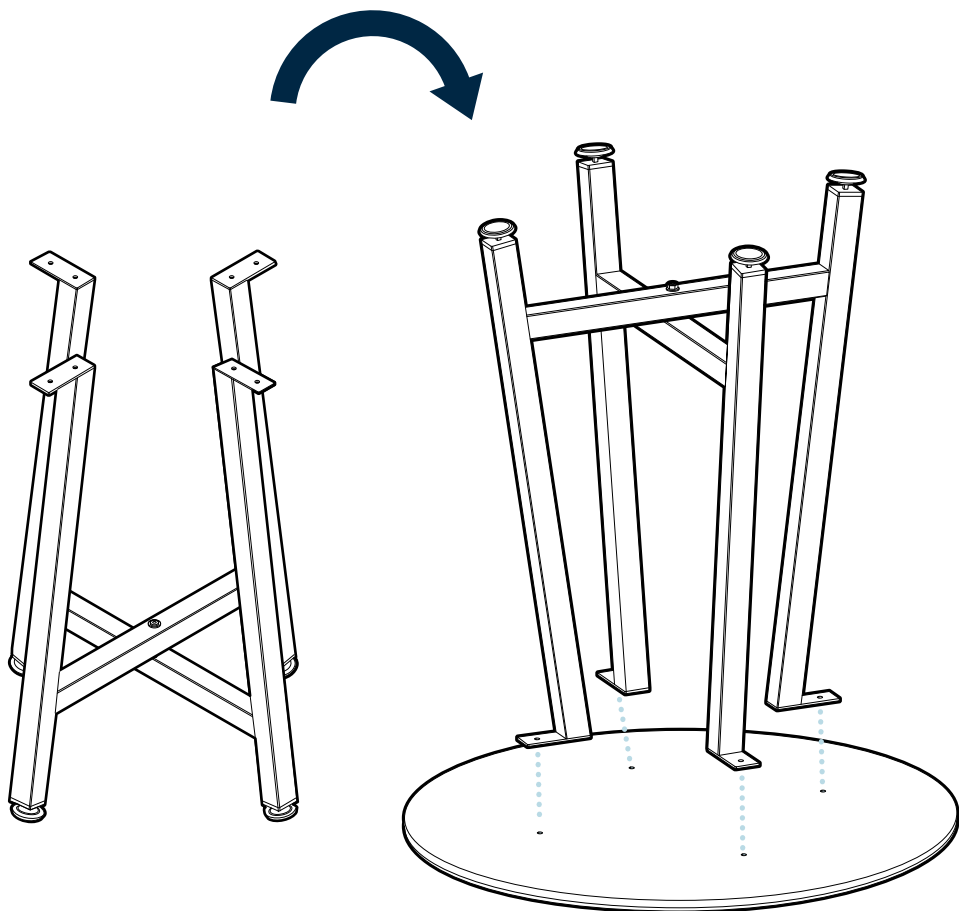
2

NOTE: We recommend assembling the table face down in the box to prevent any surface scratching.

Flip the assembled legs over, aligning the holes in the frame with the pre-drilled connection points on the underside of the table top.

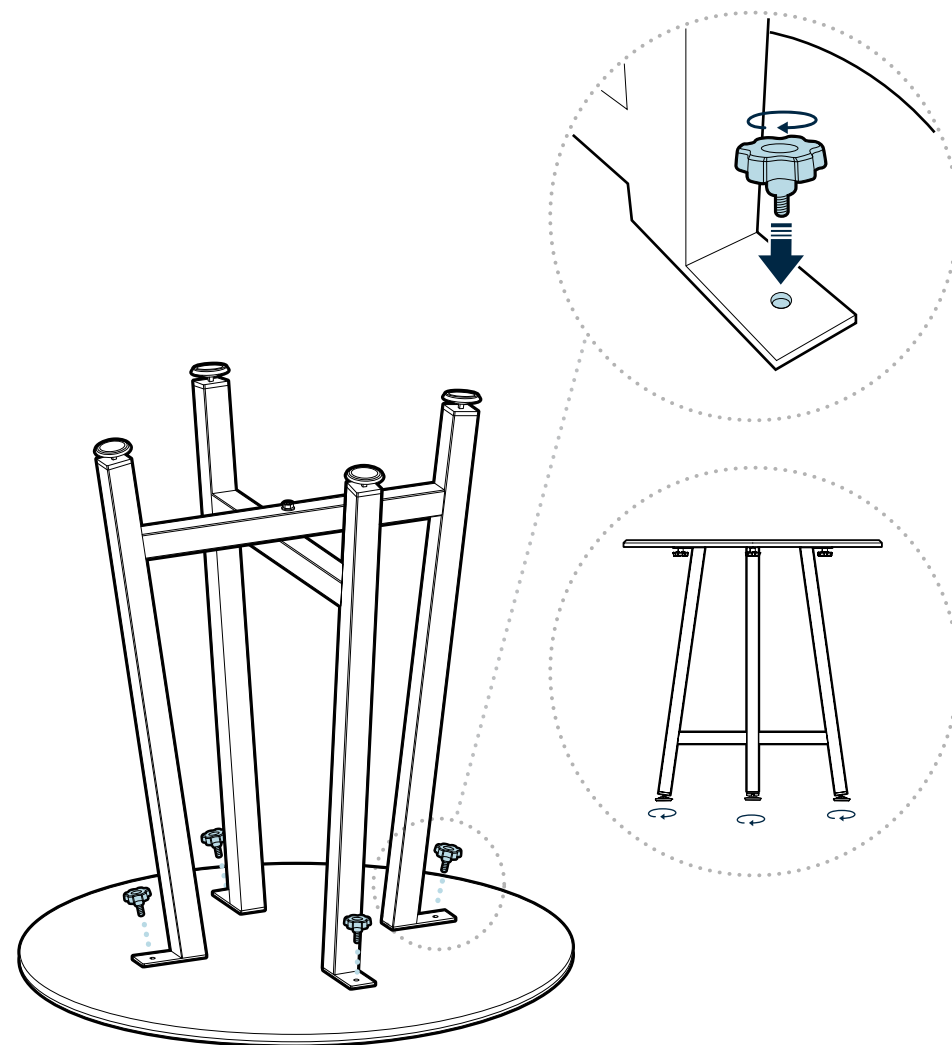
3

Use the hand bolts to fasten the legs to the table top, and tighten until firmly in place. With the assistance of another person, lift and flip the assembled table to an upright position.

Adjust the footpads to level the table as needed.

