

Standing Round Table



No Tools
Required



2 People
Required



Holds up to
300 lb (136 kg)

vari®

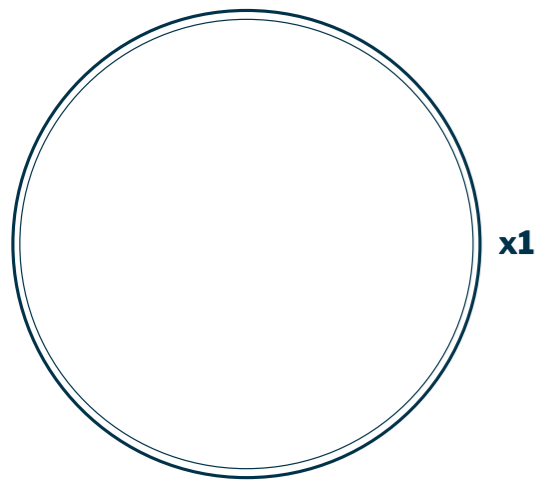

x1

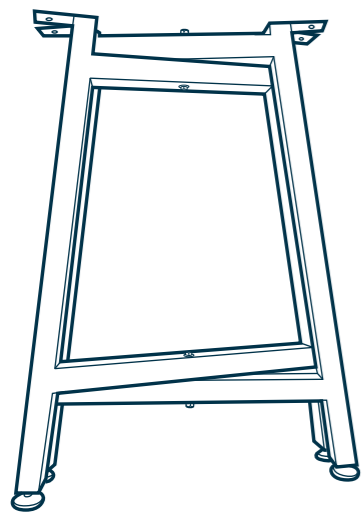

x1

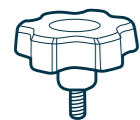

x4

1

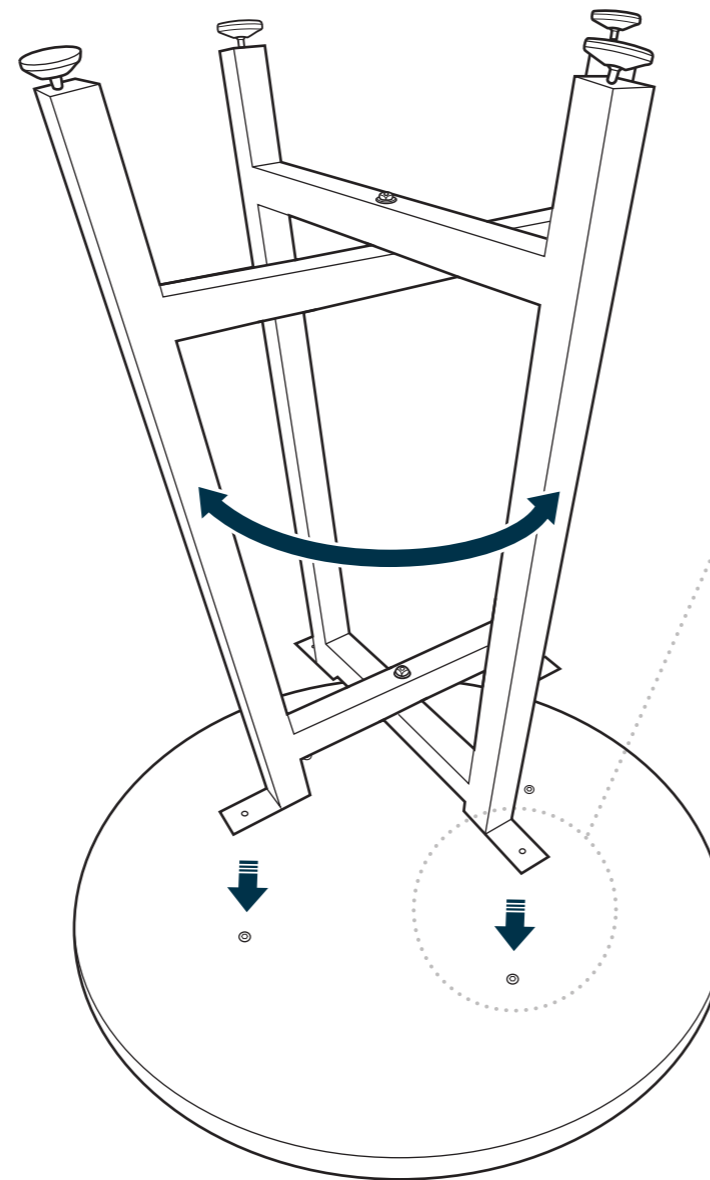
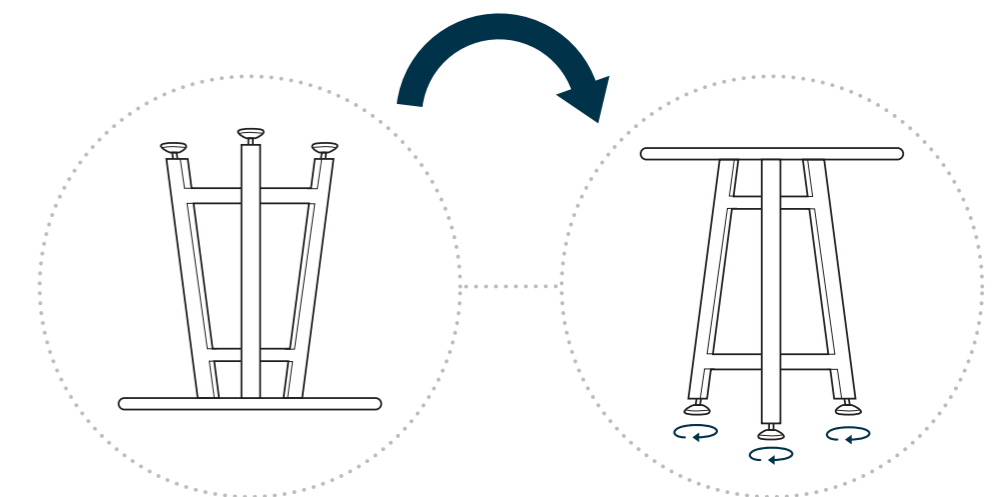
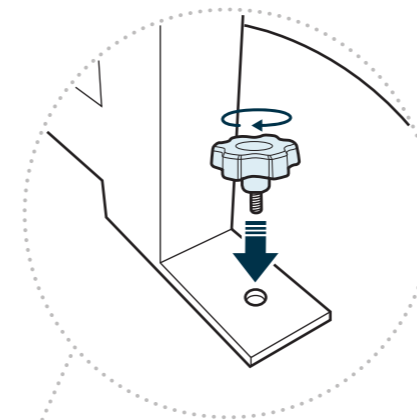

Table top and table legs will arrive in separate boxes. We recommend assembling the table face down in the box to prevent any surface scratching.

Unbox the legs, pull apart to create an "X" with the frame, and line up with table top connection points. Use the hand bolts to fasten the legs to the table top and tighten until firmly in place.

2



Two people should lift and flip the assembled table to an upright position. Adjust the footpads to level the table as needed.



(800) 207-2587



WARNING: Risk of finger injury – pinching hazard.
Use caution when folding or assembling base.